

# HYDRONIC HEATING EQUIPMENT

Application Manual



## HORIZONTAL AND VERTICAL STEAM/HOT WATER UNIT HEATERS



# Contents

	PAGE
<b>APPLICATION OF UNIT HEATERS</b>	<b>2</b>
<b>HORIZONTAL UNIT HEATERS</b>	<b>3</b>
Steam Performance Data	<b>4</b>
Steam Calculation and Correction Factors	<b>5</b>
Hot Water Performance Data	<b>6</b>
Hot Water Calculation and Correction Factors	<b>7</b>
Technical Data	<b>8</b>
Mounting Heights and Throws	<b>9</b>
Dimensional Data	<b>10</b>
Standard Specifications	<b>11</b>
<b>SERPENTINE COIL DIMENSIONAL DATA</b>	<b>12</b>
Serpentine Specification	<b>12</b>
<b>MOTOR CHARACTERISTICS - HORIZONTAL MODELS</b>	<b>13</b>
<b>VERTICAL UNIT HEATERS</b>	<b>14</b>
Steam Performance Data	<b>15-16</b>
Steam Calculations and Correction Factors	<b>17</b>
Hot Water Performance Data – Standard Output	<b>18-19</b>
Hot Water Performance Data – Low Output	<b>20-21</b>
Hot Water Calculations and Correction Factors	<b>22</b>
Dimensional Data	<b>23</b>
Mounting Heights and Throws	<b>24</b>
Motor Characteristics	<b>25</b>
<b>PIPING AND INSTALLATION</b>	<b>26</b>
<b>HORIZONTAL AND VERTICAL MODELS</b>	<b>27</b>
<b>WIRING DIAGRAMS</b>	<b>27</b>
<b>HORIZONTAL AND VERTICAL MODELS</b>	<b>27</b>
<b>WARRANTIES AND TERMS OF SALE</b>	<b>27</b>
<b>MODEL NUMBER DESCRIPTION</b>	<b>28</b>

## Application of Unit Heaters

The proper choice and placement of a unit heater with regard to building type (architecturally) and application (area use) are two criteria, the importance of which cannot be overemphasized.

The first step in the design of a job is typically to determine the heat loss before considering CFM, final air temperature and quantity and location of units. ASHRAE and others publish the basic methodology used in calculating the building or area's heat loss.

Two requirements which not only affect the heat loss calculation but every other step of the job as well, are a detailed knowledge of the building's construction and its planned usage. The number of people, types of equipment and daily activities therein should be a strong guiding factor in the overall design.

Horizontal steam/hot water unit heaters are available in a range of outputs and airflows allowing almost unlimited flexibility in job design.

The following points offer some basic guidelines and suggestions which will be helpful in designing any job using horizontal steam/hot water unit heaters:

- Always direct airflow to areas of greatest heat loss.
- Adjust throw length with horizontal louvers.
- Use horizontal and vertical louvers for complete directional control of airflow.
- Mount units at the lowest practical and allowable level.
- Select lower CFM models for lower mounting heights and heavily occupied areas.
- The higher a unit must be located, the more CFM is required to get the heat down to the occupied zone.
- More, smaller units will provide better heat distribution than fewer larger ones.
- Watch final air temperatures on units mounted at lower levels or in heavily occupied areas to insure that air is warm enough to avoid drafts being felt.
- On motors with variable speed control use lower CFM rating for design base.
- Watch sound ratings.

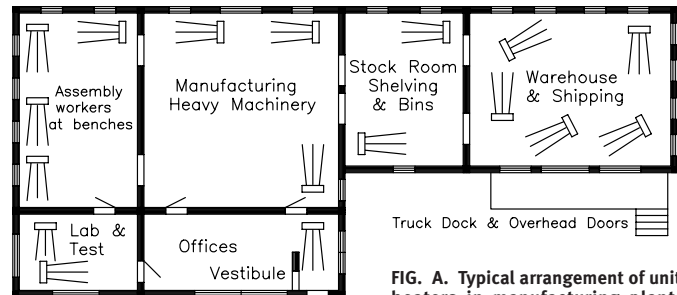
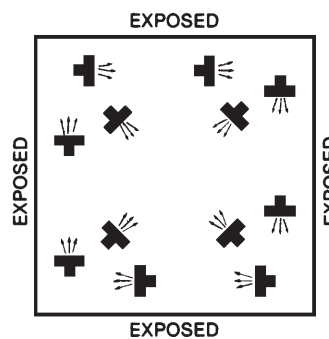
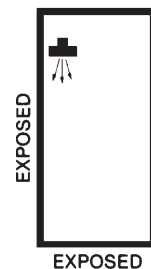

FIG. A. Typical arrangement of unit heaters in manufacturing plant, showing air flow patterns. Not to scale.



A large square area with exposed walls and roof; units are blanketing all exposed surfaces.

A narrow area with two exposed walls either with or without roof exposure.



A small area with exposed walls requiring one unit.

# Horizontal Unit Heaters Construction and Features

## MOTORS

115 volt, single speed motors are standard. Most sizes can be supplied with single phase, explosion proof motors. For standard motors in 230 volt or three-phase configuration, and three-phase explosion-proof motors, see page 13 for availability.

## FAN GUARDS

All sizes with standard (non-explosion-proof) single phase 115 or 230 volt motors utilize a wire fan guard as a motor mount. OSHA type fan guards are standard on all serpentine coil models and header type sizes 18 through 48 equipped with single phase, standard motors only. On header type sizes 60 through 360, OSHA type fan guards can be added as an optional accessory when equipped with a single phase, standard motor only. Horizontal unit heaters with OSHA fan guards can be installed in residential applications. All sizes with three-phase or explosion-proof motors are shelf-mounted and standard fan guards can be added as an optional accessory.

## HORIZONTAL AND VERTICAL LOUVERS

Horizontal louvers are standard on all sizes. Vertical louvers are an optional accessory on all sizes. Vertical louvers are installed on built to order units or shipped loose for field installation.

## THERMOSTATS

Line voltage wall thermostats are in stock for immediate shipment. All models are 115V, SPST with bi-metal thermometer, set point adjustment, 40 to 90°F (5 to 30°C) range and selector switches. Standard duty models with “off-auto” and “auto-off-fan” and a heavy duty model with “auto-off-fan” switching are available. Other models available on request.

## STRAP-ON WATER CONTROL

A SPDT strap-on type hot water control with 100° to 240°F (38 to 116°C) rated at 10 amps at 120 volt is also available. Control can be used for direct or reverse acting applications as a high or low limit.

## STEAM PRESSURE CONTROL

SPST switch opens on a rise in pressure. Control is automatically reset, has a range of 0 to 15 PSIG (0 to 103 KPa) and has an adjustable differential. **Other actions, ranges, circuits and manual reset models are available on request.**

Figure 1

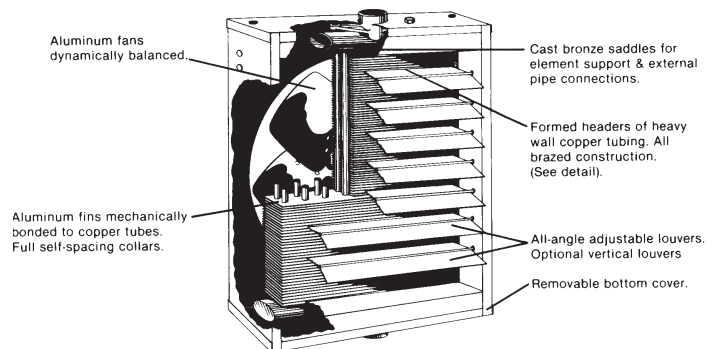
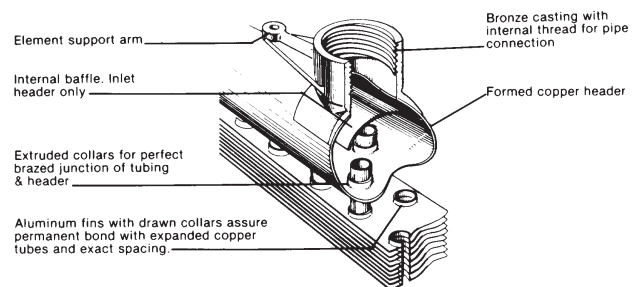

Figure 2



## MANUAL STARTERS

Single and three-phase models are available. Standard models are single-speed, toggle-operated, NEMA Type 1 and are surface-mounted. **Note: While these manual starters can be used with explosion-proof motors, they do not meet requirements for use in explosion-proof applications.**

## WALL MOUNTED SPEED CONTROLLERS

Horizontal units up to size 108 and vertical units up to size 104 with standard motors (115 volt) can be operated at reduced speeds by addition of optional speed controller. Controller is 5 amps, pre-set at factory for maximum and minimum speeds, with intermediate speeds infinitely controllable.

All 1/3, 1/2 HP and 230 volt motors operate only at rated speed and CFM – See performance data charts.

# Horizontal Unit Heaters

## Steam Performance Data – Table 1

Performance based on 2 Lbs steam pressure (13.8 kPa) at heater with air entering @ 60°F (16°C). Maximum Working Pressure 150 PSI (1034 kPa), 320°F (160°C)\*\*

Unit Size	Output BTU/HR* (kW)	Cond. lbs./hr. (kg/hr)	EDR Sq. Ft. (sq. m)	Final Air °F (°C)	Motor HP (kW)	Motor RPM	Nominal CFM (m <sup>3</sup> /s)	Outlet FPM (m/s)	Nominal Amps @ 115VAC†	Nominal Fan Diameter Inches (mm)
18	18,000 (5.3)	18.0 (8.2)	75 (7.0)	102 (39)	16 Watts	1550	395 (.186)	395 (2.007)	0.80	9 (228.6)
	16,200 (4.7)	16.2 (7.3)	68 (6.3)	105 (41)		1350	330 (.156)	330 (1.676)		9 (228.6)
24	24,000 (7.0)	24.5 (11.1)	100 (9.3)	109 (43)	16 Watts	1550	450 (.212)	450 (2.286)	0.80	10 (254.0)
	21,600 (6.3)	22.0 (10.0)	90 (8.4)	112 (44)		1350	380 (.179)	380 (1.930)		10 (254.0)
36	36,000 (10.5)	37.0 (16.8)	150 (13.9)	119 (48)	25 Watts	1550	550 (.260)	550 (2.794)	1.2	10 (254.0)
	32,400 (9.5)	33.0 (14.9)	135 (12.5)	120 (49)		1350	480 (.227)	480 (2.438)		10 (254.0)
48	48,000 (14.1)	49.0 (22.2)	200 (18.6)	119 (48)	1/20 (.037)	1000	750 (.354)	550 (2.794)	1.4	12 (304.8)
	43,200 (12.7)	44.0 (19.9)	180 (16.7)	123 (51)		900	630 (.297)	460 (2.337)		12 (304.8)
60	60,000 (17.6)	61.0 (27.6)	250 (23.2)	121 (49)	1/20 (.037)	1000	900 (.425)	650 (3.302)	1.4	12 (304.8)
	54,000 (15.8)	55.0 (24.9)	225 (20.9)	131 (55)		900	700 (.330)	510 (2.591)		12 (304.8)
72	72,000 (21.1)	73.0 (33.1)	300 (27.9)	120 (49)	1/20 (.037)	1000	1100 (.519)	800 (4.064)	1.4	14 (355.6)
	64,800 (19.0)	66.0 (29.9)	270 (25.1)	123 (51)		900	950 (.448)	700 (3.556)		14 (355.6)
84	84,000 (24.6)	85.0 (38.5)	350 (32.5)	115 (46)	1/12 (.062)	1000	1400 (.661)	900 (4.572)	2.2	14 (355.6)
	75,600 (22.2)	76.0 (34.4)	315 (29.3)	123 (51)		900	1100 (.519)	750 (3.810)		14 (355.6)
96	96,000 (28.1)	97.0 (43.9)	400 (37.2)	123 (51)	1/12 (.062)	1000	1400 (.661)	930 (4.724)	2.2	16 (406.4)
	86,400 (25.3)	88.0 (39.9)	360 (33.4)	132 (56)		900	1100 (.519)	800 (4.064)		16 (406.4)
108	108,000 (31.6)	110.0 (49.8)	450 (41.8)	115 (46)	1/12 (.062)	1000	1800 (.850)	1000 (5.080)	2.2	16 (406.4)
	97,200 (28.5)	98.0 (44.4)	405 (37.6)	120 (49)		900	1500 (.708)	900 (4.572)		16 (406.4)
120	120,000 (35.2)	122.0 (55.3)	500 (46.5)	118 (48)	1/3 (.249)	1140	1900 (.897)	900 (4.572)	4.5	18 (457.2)
132	132,000 (38.7)	134.0 (60.7)	550 (51.1)	121 (49)	1/3 (.249)	1140	2000 (.944)	950 (4.826)	4.5	18 (457.2)
144	144,000 (42.2)	146.0 (66.1)	600 (55.7)	120 (49)	1/3 (.249)	1140	2200 (1.038)	1000 (5.080)	4.5	18 (457.2)
156	156,000 (45.7)	160.0 (72.5)	650 (60.4)	115 (46)	1/3 (.249)	1140	2600 (1.227)	1150 (5.842)	4.5	18 (457.2)
180	180,000 (52.7)	190.0 (86.1)	770 (71.5)	135 (57)	1/3 (.249)	1140	2200 (1.038)	800 (4.064)	4.5	18 (457.2)
204	204,000 (59.8)	208.0 (94.2)	850 (79.0)	124 (51)	1/3 (.249)	1140	2900 (1.369)	1000 (5.080)	4.5	18 (457.2)
240	240,000 (70.3)	244.0 (110.5)	1000 (92.9)	123 (51)	1/3 (.249)	1140	3500 (1.652)	900 (4.572)	4.5	20 (508.0)
280	280,000 (82.0)	280.0 (126.8)	1100 (102.2)	121 (49)	1/2 (.373)	1100	4200 (1.982)	980 (4.978)	5.4	20 (508.0)
300	300,000 (87.9)	310.0 (140.4)	1250 (116.1)	117 (47)	1/2 (.373)	1100	5000 (2.360)	700 (3.556)	5.4	24 (609.6)
360	360,000 (105.5)	366.0 (165.8)	1500 (139.4)	120 (49)	1/2 (.373)	1100	5500 (2.596)	1000 (5.080)	5.4	24 (609.6)

\* For the lower output, an optional Speed Controller must be ordered.

For Sound Ratings See Pages 6 & 8.

\*\* For further information see page 11, COIL SIZES.

† Stated AMP is full load amps (FLA). AMP draw varies by motor manufacturer ± .2 AMPS. See page 13 for motor data.

‡ Motor HP listed is applicable to standard motor type only. For explosion proof motor HP, see unit installation manual.

# Horizontal Unit Heaters Steam Calculations and Correction Factors

**EXAMPLE: –**  
 UNIT SIZE: \_\_\_\_\_ 24  
 Steam Pressure \_\_\_\_ 10 PSI  
 Entering Air Temp. \_\_\_\_ 40°F

<b>I. CAPACITY</b> A. For 2 LBS steam, 60°F entering air	Read output directly from Table 1, 24,000 BTU/HR (Ref., Std. Unit Size 24)	
B. For higher steam pressures and/or EAT's above or below 60°F	Multiply output from Table 1 by appropriate correction factor from Table 2 (below)	24,000 x 1.29 = 30,960 BTU/HR
<b>II. FINAL AIR TEMPERATURE</b> A. For 2 LBS steam, 60°F entering air	Read temperature directly from Table 1, 109°F (Ref., Std. Unit Size 24)	
B. For capacities calculated in IB (above)	$\frac{\text{Output from IB}}{1.085 \times \text{CFM from Table 1}} + \text{EAT} = \text{Final Air Temperature}$	$\frac{30,960}{1.085 \times 450} + 40 = 103.4^\circ\text{F}$
<b>III. FINAL AIR VOLUME</b> A. For 2 LBS steam, 60°F entering air	$\frac{460 + \text{Final Air Temp from Table 1}}{530} \times \text{Nom. CFM from Table 1} = \text{Final Air Volume}$	$\frac{460 + 109}{530} \times 450 = 483 \text{ CFM}$
B. For final air temperatures calculated in IIB (above)	$\frac{460 + \text{Final Air Temp from IIB}}{530} \times \text{Nom. CFM from Table 1} = \text{Final Air Volume}$	$\frac{460 + 103.4}{530} \times 450 = 478 \text{ CFM}$
<b>IV. CONDENSATE PER HOUR</b> A. For 2 LBS steam, 60°F entering air	Read LBS per hour from Table 1, 24.5 LBS/HR (Ref., Std. Unit Size 24)	
B. For capacities calculated in IB (above)	$\frac{\text{Output from IB}}{\text{Latent Heat From Table 3}} = \text{LBS per hour of condensate}$	$\frac{30,960}{953} = 32.5 \text{ LBS/HR}$

**Table 2 – STEAM CORRECTION FACTORS BASED ON 2 PSI (13.8 kPa) STEAM AND 60°F (16°C) EAT**

ENTERING AIR TEMPERATURE °F (°C)	STEAM PRESSURE (SATURATED) – LBS PER SQUARE INCH (kPa)												
	0 (0)	2 (13.8)	5 (34.5)	10 (68.9)	15 (103.4)	20 (137.9)	30 (206.8)	40 (275.8)	50 (344.7)	75 (517.1)	100 (689.4)	125 (861.8)	150 (1,034.1)
30 (-1)	1.19	1.24	1.29	1.38	1.44	1.50	1.60	1.68	1.70	1.90	2.02	2.11	2.20
40 (4)	1.11	1.16	1.21	1.29	1.34	1.42	1.51	1.60	1.66	1.81	1.93	2.02	2.11
50 (10)	1.03	1.08	1.13	1.21	1.28	1.33	1.43	1.51	1.58	1.72	1.84	1.93	2.02
60 (16)	0.96	1.00	1.05	1.13	1.19	1.25	1.35	1.43	1.50	1.64	1.75	1.84	1.93
70 (21)	0.88	0.93	0.97	1.06	1.12	1.17	1.27	1.35	1.42	1.55	1.66	1.76	1.84
80 (27)	0.81	0.85	0.90	0.98	1.04	1.10	1.19	1.27	1.34	1.47	1.58	1.68	1.76
90 (32)	0.74	0.78	0.83	0.91	0.97	1.02	1.12	1.19	1.26	1.39	1.50	1.59	1.67
100 (38)	0.67	0.71	0.76	0.84	0.89	0.95	1.04	1.12	1.19	1.32	1.42	1.51	1.59

**Table 3 – PROPERTIES OF SATURATED STEAM**

	STEAM PRESSURE IN PSIG (kPa)												
	0 (0)	2 (13.8)	5 (34.5)	10 (68.9)	15 (103.4)	20 (137.9)	30 (206.8)	40 (275.8)	50 (344.7)	75 (517.1)	100 (689.4)	125 (891.8)	150 (1,034.1)
Steam Pressure psi (kPa)	0 (0)	2 (13.8)	5 (34.5)	10 (68.9)	15 (103.4)	20 (137.9)	30 (206.8)	40 (275.8)	50 (344.7)	75 (517.1)	100 (689.4)	125 (891.8)	150 (1,034.1)
Steam Temperature °F (°C)	212 (100)	218.5 (103.6)	227.1 (108.4)	239.4 (115.2)	249.8 (121.0)	258.8 (126.0)	274.0 (134.4)	286.7 (141.5)	297.7 (147.6)	319.9 (159.9)	337.9 (169.9)	352.9 (178.3)	365.9 (185.5)
Latent Heat of Steam Btu/lbm (KJ/Kg)	970 (2256)	966 (2247)	961 (2235)	953 (2217)	946 (2200)	940 (2186)	929 (2161)	920 (2140)	912 (2121)	891 (2072)	881 (2049)	868 (2019)	857 (1993)

# Horizontal Unit Heaters

## Hot Water Performance Data — Table 4

Performance based on 200°F (93°C) EWT, 60°F (16°C) EAT, 20°F (11°C) TD

Unit Size	Output BTU/HR* (kW)	Flow Rate GPM (L/s)	Final Air °F (°C)	Pressure Drop FT./H <sub>2</sub> O (m/water)	Motor HP (kW)	Motor RPM	Nominal CFM (m <sup>3</sup> /s)	Outlet FPM (m/s)	Nominal Amps @ 115VAC†	Sound Rating
108A	8,030 (2.4)	0.8 (.050)	91 (33)	0.80 (.244)	16 Watts	1550	245 (.116)	250 (1.270)	0.80	II
	6,800 (2.0)		90 (32)			1350	210 (.099)	215 (1.092)		I
118A	18,400 (5.4)	1.9 (.120)	94 (34)	2.20 (.671)	16 Watts	1550	500 (.236)	500 (2.540)	0.80	II
	15,650 (4.6)		96 (36)			1350	420 (.198)	420 (2.134)		I
125A	24,800 (7.3)	2.5 (.158)	102 (39)	2.20 (.671)	25 Watts	1550	580 (.274)	590 (2.997)	1.2	II
	21,230 (6.2)		106 (41)			1350	460 (.217)	450 (2.286)		I
136A	35,900 (10.5)	3.6 (.227)	99 (37)	3.00 (.914)	1/20 (.037)	1000	850 (.401)	550 (2.794)	1.4	II
	32,300 (9.5)		100 (38)			900	750 (.354)	480 (2.438)		I
18	13,050 (3.8)	1.3 (.082)	95 (35)	0.005 (.002)	16 Watts	1550	395 (.186)	395 (2.007)	0.80	II
	11,725 (3.4)		99 (37)			1350	350 (.165)	350 (1.778)		I
24	17,400 (5.1)	1.8 (.114)	96 (36)	0.014 (.004)	16 Watts	1550	450 (.212)	450 (2.286)	0.80	II
	15,600 (4.6)		98 (37)			1350	380 (.179)	380 (1.930)		I
36	26,100 (7.6)	2.7 (.170)	103 (39)	0.09 (.027)	25 Watts	1550	550 (.260)	550 (2.794)	1.2	II
	23,500 (6.9)		103 (39)			1350	480 (.227)	480 (2.438)		I
48	34,800 (10.2)	3.5 (.221)	103 (39)	0.12 (.037)	1/20 (.037)	1000	750 (.354)	550 (2.794)	1.4	II
	31,300 (9.2)		111 (44)			900	630 (.297)	460 (2.337)		I
60	43,600 (12.8)	4.4 (.278)	105 (41)	0.17 (.052)	1/20 (.037)	1000	900 (.425)	650 (3.302)	1.4	II
	39,200 (11.5)		112 (44)			900	700 (.330)	510 (2.591)		I
72	52,300 (15.3)	5.3 (.334)	104 (40)	0.23 (.070)	1/20 (.037)	1000	1100 (.519)	800 (4.064)	1.4	II
	47,000 (13.8)		106 (41)			900	950 (.448)	700 (3.556)		I
84	61,000 (17.9)	6.1 (.385)	100 (38)	0.24 (.073)	1/12 (.062)	1000	1400 (.661)	900 (4.572)	2.2	III
	54,900 (16.1)		106 (41)			900	1100 (.519)	750 (3.810)		II
96	69,700 (20.4)	7.0 (.442)	106 (41)	0.29 (.088)	1/12 (.062)	1000	1400 (.661)	930 (4.724)	2.2	III
	62,700 (18.4)		113 (45)			900	1100 (.519)	800 (4.064)		II
108	78,400 (23.0)	7.9 (.498)	100 (38)	0.36 (.110)	1/12 (.062)	1000	1800 (.850)	1000 (5.080)	2.2	III
	70,500 (20.7)		103 (39)			900	1500 (.708)	900 (4.572)		II
120	87,100 (25.5)	8.8 (.555)	102 (39)	0.39 (.119)	1/3 (.249)	1140	1900 (.897)	900 (4.572)	4.5	III
132	95,800 (28.1)	9.6 (.606)	104 (40)	0.41 (.125)	1/3 (.249)	1140	2000 (.944)	950 (4.826)	4.5	IV
144	104,000 (30.5)	10.4 (.656)	104 (40)	0.43 (.131)	1/3 (.249)	1140	2200 (1.038)	1000 (5.080)	4.5	IV
156	113,000 (33.1)	11.3 (.713)	100 (38)	0.53 (.162)	1/3 (.249)	1140	2600 (1.227)	1150 (5.842)	4.5	IV
180	118,000 (34.6)	11.8 (.744)	110 (43)	0.6 (.183)	1/3 (.249)	1140	2200 (1.038)	800 (4.064)	4.5	III
204	148,000 (43.4)	14.9 (.940)	107 (42)	0.79 (.241)	1/3 (.249)	1140	2900 (1.369)	1000 (5.080)	4.5	IV
240	174,000 (51.0)	17.4 (1.098)	106 (41)	1.06 (.323)	1/3 (.249)	1140	3500 (1.652)	900 (4.572)	4.5	IV
280	209,100 (61.3)	21.0 (1.325)	106 (41)	1.33 (.405)	1/2 (.373)	1100	4200 (1.982)	980 (4.978)	5.4	IV
300	230,000 (67.4)	23.0 (1.451)	102 (39)	2.1 (.640)	1/2 (.373)	1100	5000 (2.360)	700 (3.556)	5.4	IV
360	261,300 (76.6)	26.2 (1.653)	103 (39)	2.1 (.640)	1/2 (.373)	1100	5500 (2.596)	1000 (5.080)	5.4	IV

\*For the lower output, an optional Speed Controller must be ordered.

For Fan Diameter See Page 4.

\*\*Stated AMP is full load amps (FLA). AMP draw varies by motor manufacturer ± .2 AMPS. See page 13 for motor data.

† Motor HP listed is applicable to standard motor type only. For explosion proof motor HP, see unit installation manual.

# Horizontal Unit Heaters Hot Water Calculations and Correction Factors

**EXAMPLE: –**  
 UNIT SIZE: \_\_\_\_\_ 24  
 Entering Water Temperature \_\_\_\_\_ 160°F  
 Entering Air Temperature \_\_\_\_\_ 40°F  
 Water Temperature Drop \_\_\_\_\_ 10°F

<b>I. CAPACITY @ 20° TD:</b> A. For 200°F EWT, 60°F EAT	Read output directly from Table 4, 17,400 BTU/HR (Ref., Std. Unit Size 24)	
B. For EWT and/or EAT above or below Standard	Multiply output from Table 4 by factor from Table 5 (below)	17,400 x .878 = 15,277 BTU/HR
<b>II. CAPACITY AT OTHER TD's</b> A. For TD's from 5 to 60°F	Multiply output obtained in IA or IB (above) by appropriate factor from Table 6 (below)	IA - 17,400 x 1.15 = 20,010 BTU/HR – OR – IB - 15,277 x 1.15 = 17,569 BTU/HR
<b>III. GPM AT OTHER TD's</b> A. For TD's from 5 to 60°F	Multiply GPM of unit for 20°F TD, from Table 4 by appropriate factor from Table 6 (below)	1.8 x 2.30 = 4.14 GPM (Applies only to units with Std. 200°F EWT, 60°F EAT) For all others calculate using formula – $GPM = \frac{BTU}{500 \times TD}$
<b>IV. CAPACITY AT OTHER RATES OF WATER FLOW</b>	Multiply output from Table 4 by factor from Table 8 (below)	
<b>V. PRESSURE LOSS AT OTHER TD's</b> A. For TD's from 5 to 60°F	Multiply PD of unit for 20°F TD, from Table 4 by appropriate factor from Table 6 (below)	.014 x 5.00 = .07 Ft. H <sub>2</sub> O

**Table 5 – HOT WATER CONVERSION FACTORS BASED ON 200°F (93°C) ENTERING WATER, 60°F (16°C) ENTERING AIR AND 20°F (11°C) TEMPERATURE DROP**

ENTERING AIR TEMPERATURE °F (°C)	ENTERING WATER TEMPERATURE – °F (°C)										
	100° (38)	120° (49)	140° (60)	160° (71)	180° (82)	200° (93)	220° (104)	240° (116)	260° (127)	280° (138)	300° (149)
30 (-1)	0.518	0.666	0.814	0.963	1.120	1.268	1.408	1.555	1.702	1.850	1.997
40 (4)	0.439	0.585	0.731	0.878	1.025	1.172	1.317	1.464	1.609	1.755	1.908
50 (10)	0.361	0.506	0.651	0.796	0.941	1.085	1.231	1.375	1.518	1.663	1.824
60 (16)	0.286	0.429	0.571	0.715	0.857	1.000	1.143	1.286	1.429	1.571	1.717
70 (21)	0.212	0.353	0.494	0.636	0.777	0.918	1.060	1.201	1.342	1.483	1.630
80 (27)	0.140	0.279	0.419	0.558	0.698	0.837	0.977	1.117	1.257	1.397	1.545
90 (32)	0.069	0.207	0.345	0.483	0.621	0.759	0.897	1.035	1.173	1.311	1.462
100 (38)	0.000	0.137	0.273	0.409	0.546	0.682	0.818	0.955	1.094	1.230	1.371

**Table 6 – HOT WATER OUTPUT, FLOW RATE AND PRESSURE LOSS FACTORS BASED ON STANDARD CONDITIONS OF 200°F (93°C) ENTERING WATER, 60°F (16°C) ENTERING AIR & 20°F (11°C) WATER DROP**

USE FACTORS FROM THIS TABLE TO OBTAIN APPROXIMATE RESULTS	TEMPERATURE DROP °F (°C)									
	5 (3)	10 (6)	15 (8)	20 (11)	25 (14)	30 (17)	40 (22)	50 (28)	60 (33)	
To obtain output for other Water Temperature Drops, multiply basic output rating by applicable Factor.	1.25	1.15	1.08	1.00	.94	.90	.83	.76	.72	
To obtain flow for other Water Temperature Drops, multiply basic rate rating by applicable Factor.*	5.00	2.30	1.44	1.00	.74	.59	.40	.30	.24	
To obtain Pressure Loss Feet (Meters) of Water for other temperature Drops, multiply Basic loss at 20°F (11°C) drop by Factor.	10.00	5.00	2.00	1.00	.60	.40	.20	.13	.07	

**Table 7 – MINIMUM WATER FLOW**

UNIT SIZE	108A	118A	125A	136A	18	24	36	48	60	72	84	96
MINIMUM GPM (L/s)	0.125 (.008)	0.125 (.008)	0.125 (.008)	0.125 (.008)	0.750 (.047)	1.240 (.078)	1.240 (.078)	1.490 (.094)	1.490 (.094)	1.620 (.102)	1.860 (.117)	3.350 (.211)
UNIT SIZE	108	120	132	144	156	180	204	240	280	300	360	
MINIMUM GPM (L/s)	3.35 (.211)	3.60 (.227)	4.09 (.258)	4.09 (.258)	4.09 (.258)	4.34 (.274)	4.34 (.274)	4.59 (.290)	4.59 (.290)	6.08 (.384)	6.08 (.384)	

**\*Table 8 – HEATING CAPACITY FACTORS FOR VARIOUS RATES OF WATER FLOW**

% of Rated Water Flow	25%	50%	75%	100%	125%	150%	175%
Heating Capacity Factor	.80	.89	.96	1.00	1.04	1.07	1.10

# Horizontal Unit Heaters Technical Data

The performance data listed on page 6 includes sound ratings. The ratings provide a guide in determining the acceptable degree of loudness in particular occupancy situations.

Certain general rules apply to specific selection of unit heaters with regard to degree of quietness (or loudness);

- The greater the fan diameter, the higher the sound level.
- The higher the motor RPM, the higher the sound level. Note that on most units the lower the speed mode results in lowering the sound rating one increment.
- Selecting a larger number of smaller units generally results in lower overall noise levels than fewer large units.

All horizontal steam and hot water unit heater motors, whether fan guard or shelf-mounted, are isolated from the mechanical mount by resilient isolators. This mounting along with balanced fan blades and excellent overall construction integrity, assures you the utmost in quiet operation.

The following table outlines sound ratings for various applications. The lower the number, the quieter the unit and the lower the sound requirement.

CATEGORY OF AREA	SOUND RATING
Apartment, assembly hall, classrooms churches, courtrooms, executive offices, hospitals, libraries, museums, theatres.	I
Dining rooms, general offices, recreation areas, small retail stores.	II
Restaurants, banks, cafeterias, department stores, public buildings, service stations.	III
Gymnasiums, health clubs, laundromats, supermarkets.	IV
Garages, small machine shops, light manufacturing.	V
Factories, foundries, steel mills.	III - VII*

\*Depending on specific use in these facilities, size of operation, etc.

## CORRECTIONS WHEN USING GLYCOL SOLUTION IN SYSTEM

	Propylene Glycol	Propylene Glycol
1. Heat transfer @180°F (82°C) with no increase in flow rate	20% solution .97* 50% solution .90*	7. Freezing Point 55% by volume - 50% -28°F (-33°C) 40% -13°F (-25°C) 30% + 4°F (-16°C) 20% +17°F (- 8°C)
2. G.P.M. Req'd. @180°F (82°C), 20°F (11°C) Δ t (no correction to pump curve)	1.10%*	*Compared to water.
3. Pump Head Req'd. @180°F (82°C) w/increase in G.P.M. 1.23%*		
4. Specify gravity (water = 1.0)	1.045-1.055*	
5. Pounds/Gallons @60°F (16°C) (water = 8.3453 Pound/Gallon)	8.77	
6. pH @ 50% by volume	9.5	

Approximate factors at varying altitudes	
Altitude	Factor
Sea level - 1000 ft. (305m)	1.00
1000 ft. - 3000 ft. (915m)	.958
3000 ft. - 5000 ft. (1524m)	.929
5000 ft. - 7000 ft. (2134m)	.900
7000 ft. - 10000 ft. (3048m)	.871

# Horizontal Unit Heaters

## Mounting Heights and Throws – Table 9

Unit Size	Maximum Mounting HT. ft (m)	Approx. Max. Throw ft (m)
108A	8 (2.4)	20 (6.1)
118A	8 (2.4)	25 (7.6)
125A	9 (2.7)	29 (8.8)
136A	9 (2.7)	29 (8.8)
18	8 (2.4)	20 (6.1)
24	8 (2.4)	24 (7.3)
36	9 (2.7)	28 (8.5)
48	9 (2.7)	30 (9.1)
60	10 (3.0)	30 (9.1)
72	10 (3.0)	29 (8.8)
84	10 (3.0)	30 (9.1)
96	11 (3.4)	38 (11.6)

Unit Size	Maximum Mounting HT. ft (m)	Approx. Max. Throw ft (m)
108	11 (3.4)	40 (12.2)
120	12 (3.7)	40 (12.2)
132	13 (4.0)	54 (16.5)
144	13 (4.0)	55 (16.8)
156	13 (4.0)	55 (16.8)
180	13 (4.0)	53 (16.2)
204	13 (4.0)	55 (16.8)
240	14 (4.3)	57 (17.4)
280	14 (4.3)	57 (17.4)
300	15 (4.6)	58 (17.7)
360	15 (4.6)	60 (18.3)

This table is based on 60°F (16°C) entering air and either 2 Lbs steam (13.8 kPa) or 200°F water with a 20°F (11°C) TD. The data is based on the higher speed CFM throughout and velocity. Care should be exercised in locating adjacent unit heaters and allowance should be made for obstructions in the air pattern and conflicting air currents from other air moving devices.

Figure 3

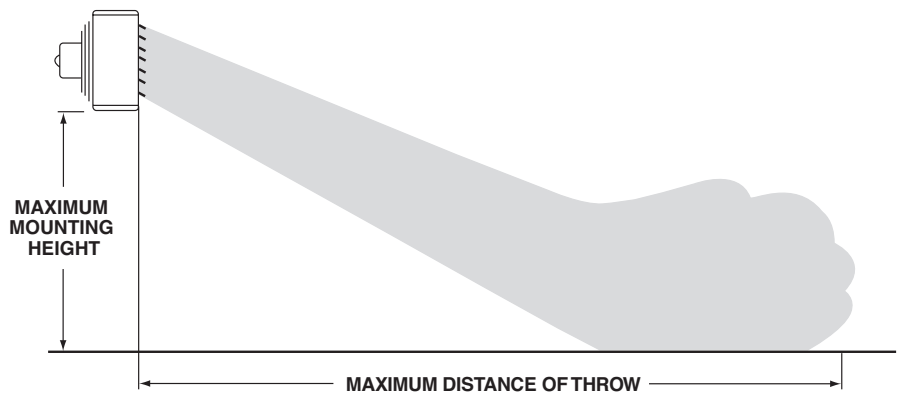

# Horizontal Unit Heaters Dimensional Data

Figure 4

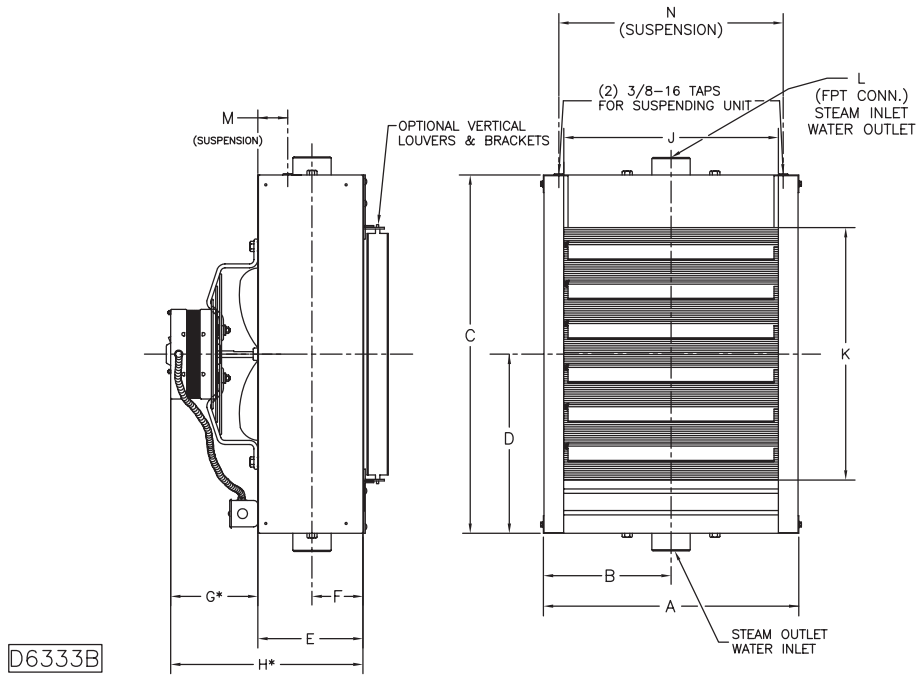

Table 10 - UNIT SIZES 18 THRU 360 (HEADER TYPE)

Unit Size	A inches (mm)	B inches (mm)	C inches (mm)	D inches (mm)	E inches (mm)	F inches (mm)	G* inches (mm)	H* inches (mm)	J inches (mm)	K inches (mm)	L inches (mm)	M inches (mm)	N inches (mm)	Number of Louvers	Nom. Fan Diam. inches (mm)	Approx. Ship Wt. lbs. (kg)
18	14 <sup>5</sup> / <sub>8</sub> (371)	7 <sup>5</sup> / <sub>16</sub> (186)	15 (381)	7 <sup>1</sup> / <sub>2</sub> (191)	6 <sup>1</sup> / <sub>8</sub> (156)	2 <sup>1</sup> / <sub>16</sub> (75)	3 <sup>1</sup> / <sub>4</sub> (83)	9 <sup>3</sup> / <sub>8</sub> (238)	12 <sup>1</sup> / <sub>4</sub> (311)	9 <sup>1</sup> / <sub>2</sub> (241)	1 <sup>1</sup> / <sub>4</sub> (32)	2 <sup>1</sup> / <sub>4</sub> (57)	12 <sup>7</sup> / <sub>8</sub> (327)	4	9 (229)	26 (11.8)
24	14 <sup>5</sup> / <sub>8</sub> (371)	7 <sup>5</sup> / <sub>16</sub> (186)	18 (457)	9 (229)	6 <sup>1</sup> / <sub>8</sub> (156)	2 <sup>1</sup> / <sub>16</sub> (75)	3 <sup>1</sup> / <sub>4</sub> (83)	9 <sup>3</sup> / <sub>8</sub> (238)	12 <sup>1</sup> / <sub>4</sub> (311)	12 <sup>1</sup> / <sub>2</sub> (318)	1 <sup>1</sup> / <sub>4</sub> (32)	2 <sup>1</sup> / <sub>4</sub> (57)	12 <sup>7</sup> / <sub>8</sub> (327)	5	10 (254)	30 (13.6)
36	17 <sup>1</sup> / <sub>8</sub> (435)	8 <sup>9</sup> / <sub>16</sub> (217)	20 <sup>1</sup> / <sub>2</sub> (521)	10 <sup>1</sup> / <sub>4</sub> (260)	5 <sup>7</sup> / <sub>8</sub> (149)	2 <sup>1</sup> / <sub>16</sub> (75)	5 <sup>1</sup> / <sub>16</sub> (144)	11 <sup>7</sup> / <sub>16</sub> (291)	14 <sup>3</sup> / <sub>4</sub> (375)	15 (381)	1 <sup>1</sup> / <sub>4</sub> (32)	1 <sup>3</sup> / <sub>4</sub> (44)	15 <sup>3</sup> / <sub>8</sub> (391)	6	12 (305)	41 (18.6)
48	17 <sup>1</sup> / <sub>8</sub> (435)	8 <sup>9</sup> / <sub>16</sub> (217)	20 <sup>1</sup> / <sub>2</sub> (521)	10 <sup>1</sup> / <sub>4</sub> (260)	5 <sup>7</sup> / <sub>8</sub> (149)	2 <sup>1</sup> / <sub>16</sub> (75)	5 <sup>1</sup> / <sub>16</sub> (129)	10 <sup>1</sup> / <sub>16</sub> (278)	14 <sup>3</sup> / <sub>4</sub> (375)	15 (381)	1 <sup>1</sup> / <sub>4</sub> (32)	1 <sup>3</sup> / <sub>4</sub> (44)	15 <sup>3</sup> / <sub>8</sub> (391)	6	12 (305)	41 (18.6)
60	18 <sup>3</sup> / <sub>8</sub> (467)	9 <sup>3</sup> / <sub>16</sub> (233)	21 <sup>3</sup> / <sub>4</sub> (552)	10 <sup>7</sup> / <sub>8</sub> (276)	6 (152)	2 <sup>1</sup> / <sub>16</sub> (75)	5 <sup>1</sup> / <sub>16</sub> (129)	11 <sup>1</sup> / <sub>16</sub> (281)	16 (406)	16 <sup>1</sup> / <sub>4</sub> (413)	1 <sup>1</sup> / <sub>4</sub> (32)	1 <sup>3</sup> / <sub>4</sub> (44)	16 <sup>5</sup> / <sub>8</sub> (422)	7	14 (356)	44 (19.9)
72	20 <sup>7</sup> / <sub>8</sub> (530)	10 <sup>7</sup> / <sub>16</sub> (265)	24 <sup>1</sup> / <sub>4</sub> (616)	12 <sup>1</sup> / <sub>8</sub> (308)	6 <sup>1</sup> / <sub>8</sub> (156)	2 <sup>1</sup> / <sub>16</sub> (75)	5 <sup>1</sup> / <sub>16</sub> (144)	11 <sup>3</sup> / <sub>16</sub> (300)	18 <sup>1</sup> / <sub>2</sub> (470)	18 <sup>3</sup> / <sub>4</sub> (476)	1 <sup>1</sup> / <sub>4</sub> (32)	1 <sup>3</sup> / <sub>4</sub> (44)	19 <sup>1</sup> / <sub>8</sub> (486)	8	14 (356)	47 (21.3)
96	19 <sup>5</sup> / <sub>8</sub> (498)	9 <sup>3</sup> / <sub>16</sub> (249)	24 (610)	12 (305)	6 <sup>5</sup> / <sub>16</sub> (160)	3 <sup>3</sup> / <sub>16</sub> (81)	7 <sup>1</sup> / <sub>2</sub> (191)	13 <sup>1</sup> / <sub>16</sub> (351)	17 <sup>1</sup> / <sub>4</sub> (438)	17 <sup>1</sup> / <sub>2</sub> (445)	1 <sup>1</sup> / <sub>2</sub> (38)	1 <sup>3</sup> / <sub>4</sub> (44)	17 <sup>7</sup> / <sub>8</sub> (454)	8	16 (406)	49 (22.2)
108	20 <sup>7</sup> / <sub>8</sub> (530)	10 <sup>7</sup> / <sub>16</sub> (265)	25 <sup>1</sup> / <sub>4</sub> (641)	12 <sup>5</sup> / <sub>8</sub> (321)	6 <sup>5</sup> / <sub>16</sub> (160)	3 <sup>3</sup> / <sub>16</sub> (81)	6 <sup>1</sup> / <sub>16</sub> (170)	13 (330)	18 <sup>1</sup> / <sub>2</sub> (470)	18 <sup>3</sup> / <sub>4</sub> (476)	1 <sup>1</sup> / <sub>2</sub> (38)	1 <sup>3</sup> / <sub>4</sub> (44)	19 <sup>1</sup> / <sub>8</sub> (486)	8	18 (457)	59 (26.7)
120	23 <sup>3</sup> / <sub>8</sub> (594)	11 <sup>1</sup> / <sub>16</sub> (297)	27 <sup>3</sup> / <sub>4</sub> (705)	13 <sup>7</sup> / <sub>8</sub> (352)	6 <sup>5</sup> / <sub>16</sub> (160)	3 <sup>3</sup> / <sub>16</sub> (81)	7 <sup>5</sup> / <sub>8</sub> (194)	14 (356)	21 (533)	21 <sup>1</sup> / <sub>4</sub> (540)	1 <sup>1</sup> / <sub>2</sub> (38)	1 <sup>3</sup> / <sub>4</sub> (44)	21 <sup>5</sup> / <sub>8</sub> (549)	9	18 (457)	74 (33.5)
144	23 <sup>3</sup> / <sub>8</sub> (594)	11 <sup>1</sup> / <sub>16</sub> (297)	27 <sup>3</sup> / <sub>4</sub> (705)	13 <sup>7</sup> / <sub>8</sub> (352)	6 <sup>5</sup> / <sub>16</sub> (160)	3 <sup>3</sup> / <sub>16</sub> (81)	7 <sup>1</sup> / <sub>16</sub> (194)	13 <sup>3</sup> / <sub>4</sub> (349)	21 (533)	21 <sup>1</sup> / <sub>4</sub> (540)	1 <sup>1</sup> / <sub>2</sub> (38)	1 <sup>3</sup> / <sub>4</sub> (44)	21 <sup>5</sup> / <sub>8</sub> (549)	9	18 (457)	74 (33.5)
156	24 <sup>5</sup> / <sub>8</sub> (625)	12 <sup>5</sup> / <sub>16</sub> (313)	29 (737)	14 <sup>1</sup> / <sub>2</sub> (368)	6 <sup>3</sup> / <sub>8</sub> (162)	3 <sup>3</sup> / <sub>16</sub> (81)	7 <sup>1</sup> / <sub>16</sub> (194)	13 <sup>3</sup> / <sub>4</sub> (349)	22 <sup>1</sup> / <sub>4</sub> (565)	22 <sup>1</sup> / <sub>2</sub> (572)	1 <sup>1</sup> / <sub>2</sub> (38)	1 <sup>3</sup> / <sub>4</sub> (44)	22 <sup>7</sup> / <sub>8</sub> (581)	9	18 (457)	90 (40.8)
180	27 <sup>7</sup> / <sub>8</sub> (708)	13 <sup>1</sup> / <sub>16</sub> (354)	30 <sup>1</sup> / <sub>4</sub> (768)	15 <sup>1</sup> / <sub>8</sub> (384)	8 <sup>1</sup> / <sub>8</sub> (206)	3 <sup>3</sup> / <sub>16</sub> (81)	5 <sup>7</sup> / <sub>8</sub> (149)	14 (356)	25 <sup>1</sup> / <sub>2</sub> (648)	23 <sup>3</sup> / <sub>4</sub> (603)	2 (51)	1 <sup>3</sup> / <sub>4</sub> (44)	26 <sup>1</sup> / <sub>8</sub> (664)	10	20 (508)	143 (65)
204	27 <sup>7</sup> / <sub>8</sub> (708)	13 <sup>1</sup> / <sub>16</sub> (354)	30 <sup>1</sup> / <sub>4</sub> (768)	15 <sup>1</sup> / <sub>8</sub> (384)	8 <sup>1</sup> / <sub>8</sub> (206)	3 <sup>3</sup> / <sub>16</sub> (81)	9 <sup>5</sup> / <sub>8</sub> (244)	17 <sup>3</sup> / <sub>4</sub> (451)	25 <sup>1</sup> / <sub>2</sub> (648)	23 <sup>3</sup> / <sub>4</sub> (603)	2 (51)	1 <sup>3</sup> / <sub>4</sub> (44)	26 <sup>1</sup> / <sub>8</sub> (664)	10	20 (508)	154 (70)
240	33 <sup>3</sup> / <sub>8</sub> (848)	16 <sup>1</sup> / <sub>16</sub> (424)	37 <sup>3</sup> / <sub>4</sub> (959)	18 <sup>7</sup> / <sub>8</sub> (479)	9 (229)	3 <sup>3</sup> / <sub>16</sub> (81)	9 <sup>5</sup> / <sub>8</sub> (244)	18 <sup>5</sup> / <sub>8</sub> (473)	31 (787)	31 <sup>1</sup> / <sub>4</sub> (794)	2 (51)	1 <sup>3</sup> / <sub>4</sub> (44)	31 <sup>5</sup> / <sub>8</sub> (803)	13	24 (610)	203 (92)
360																

\* Applies to standard motor with standard fan guard. When optional motors or OSHA fan guards are requested, dimensions will vary according to the substitutions made.

- NOTES: 1. OSHA guard standard on all serpentine models and header models 18 thru 48 supplied with 1 phase motors (dimensions shown in tables).  
 2. Standard motor and standard guard shown.  
 3. All 3 phase and explosion proof motors are shelf mounted.  
 4. Optional OSHA guards available for all units with standard 1 phase motor.

# Horizontal Unit Heaters Specifications

## GENERAL

Furnish and install, where indicated or scheduled on plans the horizontal steam/hot water unit heater. Unit shall be equipped as specified herein. All units shall be installed in a neat and workmanlike manner in accordance with this specification and the manufacturer's installation instruction.

## CASING

Casings shall be 20-gauge die-formed steel. Paint finish shall be of lead-free, chromate free, polyester melamine resin base. Finish shall be baked at 400°F.

## COIL SIZES 18 – 360

Coil elements and headers shall be of heavy wall drawn seamless copper tubing. Element tubes shall be brazed into extruded header junctions. Pipe connection saddles shall be of cast bronze. Aluminum fins shall have drawn collars to assure permanent bond with expanded element tubes and exact spacing. All Element Assemblies are submersion tested at the factory at 200 PSI (1379 kPa). Under maximum conditions in the U.S., coils are rated for 150 PSI (1034 kPa) for steam pressure and up to 150 PSI (1034 kPa) or 320°F (160°C) for hot water. Under maximum conditions in Canada, coils are rated for 15 PSI (103 kPa) for steam pressure and up to 150 PSI (1034 kPa) or 320°F (160°C) for hot water. We recommend a maximum operating pressure of 75 PSI (517 kPa) at 320°F (160°C) for long life.

## MOTORS

Motors shall be totally enclosed, resilient mounted with class "B" windings. All motors shall be designed for horizontal mounting. Motors under 1/3 HP are totally enclosed, frame mounted, 115/1/60 with thermal overload protection and permanently lubricated sleeve bearings with optional solid state speed controller available. 1/3 HP (115/1/60) motors are open frame construction, with thermal overload protection and ball bearings. 1/3 HP at (230 volt) and 1/2 HP (230 volt) motors are open frame construction, with thermal overload protection and ball bearings. 1/3 and 1/2 HP motors are available in single and 3 phase in open frame construction or explosion-proof housings, all the above are available as options.

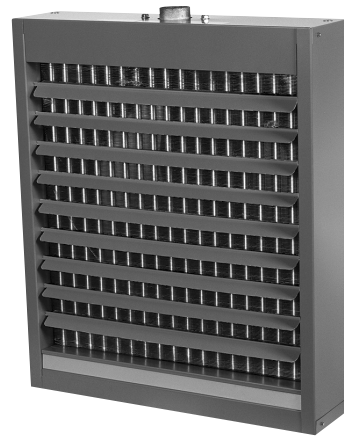

## EXPLOSION PROOF MOTORS

An enclosed motor whose enclosure is designed and constructed to withstand an explosion of a specific gas or vapor which may occur within the motor and to prevent the ignition of this gas or vapor surrounding the machine.

Horizontal unit heater motors comply with the National Electrical Code classification as follows:

- Class I, Group D; all sizes
- Class II, Group F; all sizes
- Class II, Group G; all sizes
- Division I & II Installations
- T-code (T3B)

Explosion proof equipment is not generally available for Class I, Groups A and B and it is necessary to isolate motors from the hazardous area. All explosion proof motors are shelf mounted.

## FANS

Fans shall be of the aluminum blade, hub type designed and balanced to assure maximum air delivery, low motor horsepower requirements and quiet operation. Blades are spark proof.

## FAN GUARDS

Fan guards shall be welded steel, zinc plated or painted. To meet ETL and OSHA requirements, units mounted below 8 feet from floor must be equipped with an OSHA fan guard. OSHA fan guards are standard on coil sizes 18 through 48 and optional on coil sizes 60 through 360 with single phase, standard motors only.

## AIR DEFLECTION LOUVERS

Units shall be equipped with horizontal, individually adjustable louvers. Vertical louvers for four-way air control shall be available as an optional extra.

# Serpentine Coil Horizontal Unit Heaters

## Dimensional Data

Figure 5

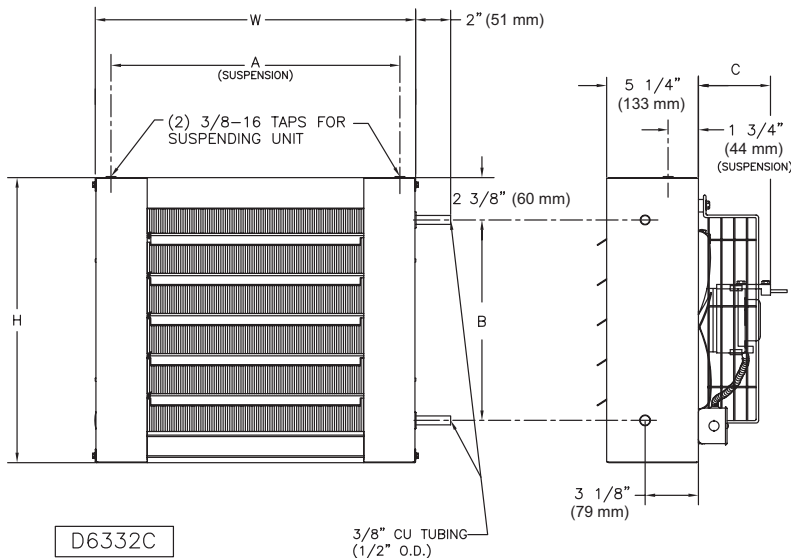

**NOTE:** Motors are totally enclosed, thermally protected, sleeve bearing, with 2" (h) x 4" (w) (51 mm [h] x 102 mm [w]) conduit connection boxes. Nutserts are attached to enclosure for balanced hanging.

Table 11 - STANDARD SPECIFICATION

Unit Size	H inches (mm)	W inches (mm)	A inches (mm)	B inches (mm)	C inches (mm)
108A	16 (406)	18 (457)	16 <sup>7</sup> / <sub>32</sub> (412)	11 <sup>1</sup> / <sub>4</sub> (286)	4 <sup>1</sup> / <sub>4</sub> (108)
118A	16 (406)	18 (457)	16 <sup>7</sup> / <sub>32</sub> (412)	11 <sup>1</sup> / <sub>4</sub> (286)	4 <sup>1</sup> / <sub>4</sub> (108)
125A	16 (406)	18 (457)	16 <sup>7</sup> / <sub>32</sub> (412)	11 <sup>1</sup> / <sub>4</sub> (286)	4 <sup>1</sup> / <sub>4</sub> (108)
136A*	18 <sup>1</sup> / <sub>2</sub> (470)	20 <sup>1</sup> / <sub>2</sub> (521)	18 <sup>22</sup> / <sub>32</sub> (475)	13 <sup>3</sup> / <sub>4</sub> (349)	5 <sup>1</sup> / <sub>16</sub> (144)

Unit Size	Number of Louvers	Nominal Fan Diameter inches (mm)	Approx. Ship Wt. lb. (kg)
108A	5	9 (229)	22 (10.0)
118A	5	10 (254)	24 (10.9)
125A	5	10 (254)	25 (11.3)
136A*	6	12 (305)	31 (14.0)

\* DIMENSION "C" IS TO BACK OF MOTOR, NOT MOTOR CONDUIT CONNECTOR AS SHOWN ABOVE.

**NOTE:** OSHA type fan guard standard on sizes 108A through 136A.

# Serpentine Coil Horizontal Unit Heaters Specifications

## GENERAL

Furnish and install, where indicated or scheduled on plans the horizontal hot water unit heater. Unit shall be equipped as specified herein. All units shall be installed in a neat and workmanlike manner in accordance with this specification and the manufacturer's installation instruction.

## CASING

Casings shall be 20-gauge die-formed steel. Paint finish shall be of lead-free, chromate free, polyester melamine resin base. Finish shall be baked at 400°F.

## COIL SIZES 108A – 136A

Coil is a serpentine design with seamless copper tubing. Aluminum fins shall have drawn collars to assure permanent bond with expanded tubes. Tubing connection shall be 3/8 inch copper tubing, type "M" (.500 OD). Coils shall be factory tested at 200 PSI (1379 kPa). Coils have a max operating entering water temperature of 320°F (160°C).

## MOTORS

Motors shall be totally enclosed, resilient mounted with class "B" windings. All motors shall be designed for horizontal mounting.

## FANS

Fans shall be of the aluminum blade type, designed and balanced to assure maximum air delivery, low motor horsepower requirements and quiet operation.

## OSHA FAN GUARDS

OSHA fan guards shall be welded steel, zinc plated or painted. OSHA fan guards are standard on all models.

## AIR DEFLECTION LOUVERS

Units shall be equipped with horizontal, individually adjustable louvers.



# Horizontal Unit Heaters Motor Characteristics

**Table 12 - TOTALLY ENCLOSED MOTOR TYPE**

Unit Sizes	AMP	MCA	HP	RPM
<b>115/1/60</b>				
18, 24, 108A, 118A	0.8	1.0	16W*	1550
136A	1.4	1.8	1/20*	1000
36, 125A	1.2	1.5	25W*	1550
48, 60, 72	1.4	1.8	1/20*	1000
84, 96, 108	2.2	2.8	1/12*	1000
120, 132, 144, 156, 180, 204, 240	4.5	5.6	1/3	1140
280, 300, 360	5.4	6.8	1/2	1100
<b>230/1/60</b>				
18, 24, 108A, 118A	0.4	0.5	16W	1550
136A	1.4	1.8	1/20†	1000
36, 125A	0.6	0.8	25W	1550
48, 60, 72	1.4	1.8	1/20†	1000
84, 96, 108	2.2	2.8	1/12†	1000
120, 132, 144, 156, 180, 204, 240	4.5	5.6	1/3†	1140
280, 300, 360	5.4	6.8	1/2†	1100
<b>208-230/460/3/60</b>				
48, 60, 72, 84, 96, 108, 120, 132, 144, 156, 180, 204, 240, 280, 300, 360	2.6-2.6/1.3	3.3-3.3/1.6	1/2**	1140

\* Optional variable speed switch is available.

\*\*These motors are without thermal overload protection. Motors without thermal overload protection must be installed with the optional manual starter or other field provided overload protection.

NOTE 1: All motors are constant speed and operate at top speed as indicated in motor data. Unit sizes 18 through 108, including 108A, 118A, 125A and 136A can be run at reduced speed with addition of optional variable speed switch. This switch is factory-calibrated for low and high speed ratings, with intermediate speeds infinitely controllable. Unit sizes 120 through 360 operate at constant speed as indicated in motor data. All 1/4 HP motors are PSC.

NOTE 2: Motors under 1/3 HP are totally enclosed, frame mounted, 115/1/60 with thermal overload protection and permanently lubricated sleeve bearings with optional speed controller available. 1/3 HP (115/1/60) motors are open frame constant speed with thermal over-load protection and ball bearings. 1/3 HP (230 volt) and 1/2 HP (230 volt) motors are open frame constant speed with thermal overload protection and ball bearings.

**Table 13 - EXPLOSION PROOF WITH THERMAL OVERLOAD MOTOR TYPE**

Unit Sizes	AMP	MCA	HP	RPM
<b>115/1/60</b>				
48, 60, 72, 84, 96, 108, 120, 132	3.7	4.6	1/6	1140
144, 156, 180, 204	5.4	6.8	1/4	1140
240	7.8	9.8	1/3***	1140
280, 300, 360	9.6	12.0	1/2***	1140
<b>230/1/60</b>				
48, 60, 72, 84, 96, 108, 120, 132	3.7	4.6	1/6†	1140
144, 156, 180, 204	5.4	6.8	1/4†	1140
240	3.9	4.9	1/3***	1140
280, 300, 360	4.8	6.0	1/2***	1140
<b>230/460/3/60</b>				
144, 156, 180, 204, 240, 280, 300, 360	2.2/1.1	2.8/1.4	1/3	1140

\*\*\*These motors are 115/230 volts.

†230/1/60 unit has 115/1/60 motor supplied with field installed stepdown transformer.

NOTE 3: 1/3 and 1/2 HP motors are available as 230 volt single and 3 phase in open frame and explosion-proof housings, all available as options. 1/3 and 1/2 HP motors operate at single speed only.

NOTE 4: Stated AMP draw is full load amp (FLA). AMP draw varies by motor manufacturer ± .2 AMPS. Verify FLA per unit motor data plate.

**CAUTION: Select appropriate AMP and MCA for the multiple voltage motors. For example, the AMP and MCA for Models 360 with a 460 volt Totally Enclosed motor is 1.3 and 1.6 respectively.**

# Vertical Unit Heaters Features and General Specifications

Vertical projection unit heaters provide heat where it is required in commercial and industrial applications. Mounted near the ceiling, this unit provides air circulation and reduces stratification, without occupying otherwise usable building space. Units can be provided with an optional diffuser for patterned discharge or without a diffuser for higher velocity 'spot' heating near doorways and other high-loss areas.

Vertical units are available in fifteen sizes for steam or hot water heating. Steam capacities range from 140 to 2,580 EDR (26.0 to 705 MBH) (2 PSI w/60°F EAT). Hot water capacities range from 18.9 to 519.4 MBH (200°F EWT/20°F drop w/60°F EAT).

## CONSTRUCTION

The unit casing is formed by two square, 20-gauge steel plates. The bottom plate forms an orifice for air delivery. Air ports are stamped in the top plate of standard units for easy conversion of low output units.

## FAN

The aluminum blade fans are quiet, factory balanced and sturdy for standard or sparkproof applications.

## OPTIONAL OSHA FAN GUARD, LOUVER CONE DIFFUSER

To meet ETL and OSHA requirements, units mounted below 8 feet (2.4 m) must be equipped with an OSHA Fan Guard. If adjustments to the vertical airflow pattern are desired, the Louver Cone Diffuser can be installed.

Note: Vertical unit heaters can support either OSHA Fan Guard or the Louver Cone Diffuser - **both options cannot be installed on the same unit.**

## HEATING ELEMENT

Hot water-steam coils are rectangular 3 or 4-sided, one-pass, multiple circuit, with aluminum fins mechanically bonded to the tubes. Standard coils are seamless .025 copper tubing. Supply and return connections are steel pipe. Coils are factory tested at 400 PSIG (2758 kPa) under water. Under maximum conditions in the U.S., coils are rated for 75 PSI (517 kPa) for steam pressure and up to 225 PSI (1551 kPa) or 325°F (162.8°C) for hot water. Under maximum conditions in Canada, coils are rated for 15 PSI (103 kPa) for steam pressure and up to 225 PSI (1551 kPa) or 325°F (162.8°C) for hot water.

## MOTORS

Standard motors are 115/60/1, totally enclosed, with thermal overload protection for all vertical units through size 285. Standard motors for sizes 40, 62 and 77 are shaded pole, sleeve bearing. The vertical 104 motor is permanent split capacitor type with sleeve bearings. Motor for unit sizes 125 through 285 are permanent split capacitor types with permanently lubricated ball bearings. Motors used on unit sizes 317 through 700 are 230/460/60/3, totally enclosed, with permanently lubricated ball bearings. Unit sizes smaller than 317 are also available with 230/460/60/3 motors.

All motors fractional HP and integral HP, have Class "B" insulation. The 115/60/1 motors used as standard on unit

sizes 40 through 104 can be operated at multiple speeds with the addition of a solid-state control.

All units are available with 1140 RPM explosion-proof motors.

## EXPLOSION PROOF MOTORS

An enclosed motor whose enclosure is designed and constructed to withstand an explosion of a specific gas or vapor which may occur within the motor and to prevent the ignition of this gas or vapor surrounding the machine.

Vertical unit heater motors comply with the National Electrical Code classification as follows:

- Class I, Group D; all sizes
- Class II, Group F; all sizes
- Class II, Group G; all sizes
- Division I & II Installations
- T-code (T3B)

Explosion proof equipment is not generally available for Class I, Groups A and B and it is necessary to isolate motors from the hazardous area.

## THERMOSTATS

Line voltage wall thermostats are in stock for immediate shipment. All models are 115V, SPST with bimetal thermometer, set point adjustment, 40 to 90°F (5 to 30°C) range and selector switches. Standard duty models with "off-auto" and "auto-off-fan" and a heavy duty model with "auto-off-fan" switching are available. Other models available on request.

## STRAP-ON WATER CONTROL

A SPDT strap-on type hot water control with 100° to 240°F (38 to 116°C) rated at 10 amps at 120 volt is also available. Control can be used for direct or reverse acting applications as a high or low limit.

## STEAM PRESSURE CONTROL

SPST switch opens on a rise in pressure. Control is automatically reset, has a range of 0 to 15 PSIG (0 to 103 kPa) and has an adjustable differential. **Other actions, ranges, circuits and manual reset models are available on request.**

## MANUAL STARTERS

Single and three-phase models are available. Standard models are single-speed, toggle-operated, NEMA Type 1 and are surface-mounted. **Note: While these manual starters can be used with explosion-proof motors, they do not meet requirements for use in explosion-proof applications.**

## WALL MOUNTED SPEED CONTROLLERS

Horizontal units up to 108 and vertical units up to 104 with standard motors (115 volt) can be operated at reduced speeds by addition of optional speed controller. Controller is 5 amps, pre-set at factory for maximum and minimum speeds, with intermediate speeds infinitely controllable. All 1/3, 1/2 HP and 230 volt motors operate only at rated speed and CFM – See performance data charts.

# Vertical Unit Heaters

## Steam Performance Data – Table 14

Performance based on 2 Lbs (13.8 kPa) steam pressure at heater with air entering @ 60°F (16°C).



### STANDARD UNITS

Unit Size	Output BTU/HR* (kW)	Condensate lbs/hr (kg/hr)	EDR Sq. ft. (Sq. m)	Final Air Temp °F (°C)	Motor		Nominal CFM (m³/s)	Outlet Velocity FPM (m/s)	Nominal Amps at 115 VAC**	Sound Rating
					HP† (kW)	RPM				
040	41,300 (12.1)	43 (19.5)	172 (16.0)	124 (51)	1/40 (.019)	1550	595 (.278)	877 (4.455)	1.2	I
	<i>33,600 (9.8)</i>	<i>55 (24.9)</i>	<i>140 (13.0)</i>	<i>131 (55)</i>		<i>1150</i>	<i>436 (.203)</i>	<i>658 (3.343)</i>		
062	65,500 (19.2)	68 (30.8)	273 (25.4)	121 (49)	1/20 (.037)	1550	989 (.462)	1005 (5.105)	2.1	II
	<i>52,800 (15.5)</i>	<i>55 (24.9)</i>	<i>220 (20.5)</i>	<i>129 (54)</i>		<i>1150</i>	<i>706 (.329)</i>	<i>727 (3.693)</i>		
077	80,600 (23.6)	83 (37.6)	336 (31.3)	122 (50)	1/20 (.037)	1550	1200 (.560)	1220 (6.198)	2.1	II
	<i>65,100 (19.1)</i>	<i>67 (30.4)</i>	<i>271 (25.2)</i>	<i>130 (54)</i>		<i>1150</i>	<i>858 (.400)</i>	<i>894 (4.542)</i>		
104	101,800 (29.8)	106 (48.0)	424 (39.4)	123 (51)	1/8 (.093)	1070	1490 (.695)	980 (4.978)	2.1	II
	<i>87,900 (25.8)</i>	<i>91 (41.2)</i>	<i>366 (34.0)</i>	<i>129 (54)</i>		<i>850</i>	<i>1180 (.551)</i>	<i>783 (3.978)</i>		
125	124,400 (36.4)	129 (58.4)	518 (48.2)	124 (51)	1/6 (.124)	1100	1790 (.835)	1170 (5.944)	2.3	III
144	152,000 (44.5)	157 (71.1)	633 (58.9)	123 (51)	1/6 (.124)	1100	2220 (1.036)	1045 (5.309)	2.3	III
164	173,000 (50.7)	179 (81.1)	720 (67.0)	121 (49)	1/6 (.124)	1100	2620 (1.223)	1230 (6.248)	2.3	IV
200	210,200 (61.6)	208 (94.2)	838 (78.0)	118 (48)	1/4 (.186)	1100	3200 (1.493)	1495 (7.595)	3.6	III
237	249,800 (73.2)	260 (117.8)	1040 (96.7)	115 (46)	1/4 (.186)	1100	4180 (1.951)	1205 (6.121)	3.6	IV
285	283,800 (83.2)	294 (133.2)	1180 (109.8)	119 (48)	1/2 (.373)	1100	4430 (2.067)	1275 (6.477)	5.4	IV
317	333,400 (97.7)	345 (156.3)	1390 (129.3)	119 (48)	3/4 (.559)	1140	5210 (2.431)	1500 (7.620)	N/A	IV
367	386,000 (113.1)	400 (181.2)	1610 (149.8)	118 (48)	3/4 (.559)	1140	6140 (2.865)	1770 (8.992)	N/A	IV
495	496,000 (145.3)	514 (232.8)	2070 (192.6)	117 (47)	1-1/2 (1.119)	1175	8020 (3.743)	1640 (8.331)	N/A	IV
585	585,000 (171.4)	605 (274.1)	2440 (227.0)	117 (47)	1-1/2 (1.119)	1175	9450 (4.410)	1930 (9.804)	N/A	IV
700	705,000 (206.6)	729 (330.2)	2940 (273.5)	119 (48)	3 (2.237)	1165	11,000 (5.133)	2250 (11.430)	N/A	IV

#### NOTES:

EDR = Equivalent Direct Radiation

Constant speed units are rated at capacities shown in regular type; capacities shown in italic faced type apply only to units with multi-speed motors.

\* To determine BTU per hour capacities at various steam pressures and entering air temperatures, use conversion factors from Table 17, page 17. Final temperatures at new conditions can be calculated by applying basic formula.

\*\* Stated AMP is full load amps (FLA). AMP draw varies by motor manufacturer ±0.2 AMPS. See Page 25 for motor data.

† Motor HP listed is applicable to standard motor type only. For explosion proof motor HP, see unit installation manual.

# Vertical Unit Heaters

## Steam Performance Data – Table 15

Performance based on 2 Lbs (13.8 kPa) steam pressure at heater with air entering @ 60°F (16°C).

LOW OUTPUT UNITS

STANDARD VERTICAL UNITS WITH ALL AIR PORTS OPEN

Unit Size	Output BTU/HR* (kW)	Condensate lbs/hr (kg/hr)	EDR Sq. ft. (Sq. m)	Final Air Temp °F (°C)	Motor		Nominal CFM (m³/s)	Outlet Velocity FPM (m/s)	Sound Rating
					HP† (kW)	RPM			
040L	34,800 (10.2)	36 (16.3)	145 (13.5)	108 (42)	1/40 (.019)	1550	668 (.312)	95 (4.826)	I
	<i>26,000 (7.6)</i>	<i>27 (12.2)</i>	<i>108 (10.0)</i>	<i>111 (44)</i>		<i>1150</i>	<i>470 (.219)</i>	<i>672 (3.414)</i>	
062L	57,200 (16.8)	59 (26.7)	238 (22.1)	104 (40)	1/20 (.037)	1550	1200 (.560)	1190 (6.045)	I
	<i>45,800 (13.4)</i>	<i>48 (21.7)</i>	<i>191 (17.8)</i>	<i>109 (43)</i>		<i>1150</i>	<i>862 (.402)</i>	<i>858 (4.359)</i>	
077L	68,000 (19.9)	71 (32.2)	283 (26.3)	106 (41)	1/20 (.037)	1550	1360 (.635)	1350 (6.858)	II
	<i>55,000 (16.1)</i>	<i>57 (25.8)</i>	<i>229 (21.3)</i>	<i>111 (44)</i>		<i>1150</i>	<i>995 (.464)</i>	<i>992 (5.039)</i>	
104L	85,400 (25.0)	89 (40.3)	356 (33.1)	108 (42)	1/8 (.093)	1070	1640 (.765)	1050 (5.334)	II
	<i>71,200 (20.9)</i>	<i>74 (33.5)</i>	<i>296 (27.5)</i>	<i>111 (44)</i>		<i>850</i>	<i>1290 (.602)</i>	<i>827 (4.201)</i>	
125L	111,000 (32.5)	115 (52.1)	462 (43.0)	107 (42)	1/6 (.124)	1100	2180 (1.017)	1390 (7.061)	III
144L	125,000 (36.6)	130 (58.9)	524 (48.7)	109 (43)	1/6 (.124)	1100	2360 (1.101)	1080 (5.486)	III
164L	149,000 (43.7)	154 (69.8)	620 (57.7)	107 (42)	1/6 (.124)	1100	2920 (1.363)	1340 (6.807)	IV
200L	176,800 (51.8)	183 (82.9)	736 (68.5)	108 (42)	1/4 (.186)	1100	3390 (1.582)	1560 (7.925)	III
237L	214,900 (63.0)	224 (101.5)	895 (83.3)	104 (40)	1/4 (.186)	1100	4500 (2.100)	1270 (6.452)	IV
285L	251,800 (73.8)	260 (117.8)	1050 (97.7)	106 (41)	1/2 (.373)	1100	5040 (2.352)	1420 (7.214)	IV
317L	291,000 (85.3)	302 (136.8)	1210 (112.6)	107 (42)	3/4 (.559)	1140	5700 (2.660)	1610 (8.179)	IV
367L	344,000 (100.8)	356 (161.3)	1430 (133.0)	108 (42)	3/4 (.559)	1140	6600 (3.080)	1870 (9.500)	IV
495L	428,000 (125.4)	446 (202.0)	1785 (166.0)	102 (39)	1-1/2 (1.119)	1175	9380 (4.377)	1860 (9.449)	IV
585L	515,000 (150.9)	533 (241.4)	2140 (199.1)	106 (41)	1-1/2 (1.119)	1175	10,300 (4.807)	2060 (10.465)	IV
700L	620,000 (181.7)	642 (290.8)	2580 (240.0)	108 (42)	3 (2.237)	1165	11,900 (5.553)	2380 (12.090)	IV

**NOTES:**

EDR = Equivalent Direct Radiation

Constant speed units are rated at capacities shown in regular type; capacities shown in italic faced type apply only to units with multi-speed motors.

To determine BTU per hour capacities at various steam pressures and entering air temperatures, use conversion factors from Table 17, page 17.

Final temperatures at new conditions can be calculated by applying basic formula.

† Motor HP listed is applicable to standard motor type only. For explosion proof motor HP, see unit installation manual.

# Vertical Unit Heaters Steam Calculations and Correction Factors

**EXAMPLE: –**  
 UNIT SIZE: \_\_\_\_\_ 40  
 Steam Pressure \_\_\_\_ 10 PSI  
 Entering Air Temp. \_\_\_\_ 40°F

<b>I. CAPACITY</b>		
A. For 2 lbs. steam, 60°F entering air	Read output directly from Tables 14 & 15: 41,300 BTU/HR	
B. For higher steam pressures and/or EAT's above or below 60°F	Multiply output from Tables 14 & 15 by appropriate correction factor from Table 16 (below)	41,300 x 1.27 = 52,451 BTU/HR
<b>II. FINAL AIR TEMPERATURE</b>		
A. For 2 LBS steam, 60°F entering air	Read temperature directly from Tables 14 & 15: 124°F	
B. For capacities calculated in IB (above)	$\frac{\text{Output from IB}}{1.085 \times \text{CFM from Table 14}} + \text{EAT} = \text{Final Air Temperature}$	$\frac{52,451}{1.085 \times 595} + 40 = 121.0^\circ\text{F}$
<b>III. FINAL AIR VOLUME</b>		
A. For 2 LBS steam, 60°F entering air	$\frac{460 + \text{Final Air Temp from Table 14}}{530} \times \text{Nom. CFM from Table 14} = \text{Final Air Volume}$	$\frac{460 + 124}{530} \times 595 = 655 \text{ CFM}$
B. For final air temperatures calculated in IIB (above)	$\frac{460 + \text{Final Air Temp from IIB}}{530} \times \text{Nom. CFM from Table 14} = \text{Final Air Volume}$	$\frac{460 + 121.0}{530} \times 595 = 652 \text{ CFM}$
<b>IV. CONDENSATE PER HOUR</b>		
A. For 2 LBS steam, 60°F entering air	Read LBS per hour from Tables 14 & 15: 43 LBS/HR	
B. For capacities calculated in IB (above)	$\frac{\text{Output from IB}}{\text{Latent Heat From Table 17}} = \text{LBS per hour of condensate}$	$\frac{52,451}{953} = 55.0 \text{ LBS/HR}$

**Table 16 – STEAM CORRECTION FACTORS BASED ON 2 LBS. STEAM (13.8 kPa) 60°F (16°C) EAT**

ENTERING AIR TEMPERATURE °F (°C)	STEAM PRESSURE (SATURATED) – LBS PER SQUARE INCH (kPa)									
	0 (.0)	2 (13.8)	5 (34.5)	10 (68.9)	15 (103.4)	20 (137.9)	30 (206.8)	40 (275.8)	50 (344.7)	75 (517.1)
30° (-1°)	1.18	1.22	1.27	1.34	1.40	1.45	1.53	1.61	1.67	1.79
40° (4°)	1.11	1.15	1.20	1.27	1.32	1.37	1.46	1.53	1.59	1.71
50° (10°)	1.03	1.07	1.12	1.19	1.25	1.30	1.39	1.46	1.52	1.64
60° (16°)	0.96	1.00	1.05	1.12	1.18	1.23	1.32	1.39	1.45	1.57
70° (21°)	0.90	0.93	0.98	1.05	1.11	1.16	1.25	1.32	1.38	1.49
80° (27°)	0.83	0.86	0.91	0.98	1.04	1.09	1.18	1.25	1.31	1.42
90° (32°)	0.76	0.80	0.85	0.91	0.97	1.02	1.11	1.18	1.24	1.36
100° (38°)	0.69	0.73	0.78	0.85	0.90	0.96	1.04	1.11	1.17	1.29

**Table 17 – PROPERTIES OF SATURATED STEAM**

	STEAM PRESSURE IN PSIG (kPa)									
	0 (.0)	2 (13.8)	5 (34.5)	10 (68.9)	15 (103.4)	20 (137.9)	30 (206.8)	40 (275.8)	50 (344.7)	75 (517.1)
Steam Temperature-°F (°C)	212.0 (100.0)	218.5 (103.6)	227.1 (108.4)	239.4 (115.2)	249.8 (121.0)	258.8 (126.0)	274.0 (134.4)	286.7 (141.5)	297.7 (147.6)	319.9 (159.9)
Latent Heat of Steam-Btu/lbm (KJ/Kg)	970 (2256)	966 (2247)	961 (2235)	953 (2217)	946 (2200)	940 (2186)	929 (2161)	920 (2140)	912 (2121)	891 (2072)

NOTE 1: Ratings apply only to free inlet and discharge without diffusers.

NOTE 2: All motors are constant speed and operate at top speed as indicated in motor data. Sizes 40 through 104 can be run at reduced speed with addition of optional variable speed switch. This switch is factory-calibrated for low and high speed ratings, with intermediate speeds infinitely controllable. Sizes 164 through 700 operate at constant speed as indicated in motor data.

NOTE 3: For specific motor data refer to motor specifications on page 25.

NOTE 4: To correct for entering air temperatures, use 1°F temperature rise for each foot in mounting height. As an example, 60°F air is required at work area (5 feet above floor) units are to be mounted at (20 feet) above floor. Mounting height (20 feet) minus work height (5 feet) equals differential (15 feet) or, 15°F rise in air temperature at unit air inlet. Correct for actual inlet air temperature of 75°F (60°F + 15°F = 75°F EAT) on Table 16.

# Vertical Unit Heaters

## Hot Water Performance Data\*\* – Table 18

### STANDARD OUTPUT UNITS

Unit Size	Water Temp Drop °F (°C)	Output MBH (kW)	Flow Rate GPM (L/s)	Pressure Drop ft/water (m/water)	Final Air Temp °F (°C)	Motor HP† (kW)	Motor RPM	Nominal CFM (m³/s)	Outlet Velocity FPM (m/s)	Sound Rating
040	10° (5.6°)	28.8 (8.4)	5.93 (.374)	.37 (.113)	104.6° (40.3°)	1/40 (.019)	1550	595 (.278)	877 (4.455)	I
	<b>20° (11.1°)</b>	<b>22.7 (6.7)</b>	<b>2.34 (.148)</b>	<b>.06 (.018)</b>	<b>95.2° (35.1°)</b>					
	30° (16.7°)	16.7 (4.9)	1.15 (.073)	.02 (.006)	85.9° (29.9°)					
040*	10° (5.6°)	22.9 (6.7)	4.71 (.297)	.24 (.073)	108.3° (42.4°)	1/40 (.019)	1150	436 (.203)	658 (3.343)	I
	<b>20° (11.1°)</b>	<b>18.1 (5.3)</b>	<b>1.87 (.118)</b>	<b>.04 (.012)</b>	<b>98.3° (36.8°)</b>					
	30° (16.7°)	13.4 (3.9)	.92 (.058)	.01 (.003)	88.4° (31.3°)					
062	10° (5.6°)	48.1 (14.1)	9.92 (.626)	1.05 (.320)	104.8° (40.4°)	1/20 (.037)	1550	989 (.462)	1005 (5.105)	II
	<b>20° (11.1°)</b>	<b>39.6 (11.6)</b>	<b>4.08 (.257)</b>	<b>.19 (.058)</b>	<b>96.9° (36.1°)</b>					
	30° (16.7°)	31.1 (9.1)	2.14 (.135)	.06 (.018)	89.0° (31.7°)					
062*	10° (5.6°)	38.1 (11.2)	7.85 (.495)	.67 (.204)	109.7° (43.2°)	1/20 (.037)	1150	706 (.329)	727 (3.693)	II
	<b>20° (11.1°)</b>	<b>31.5 (9.2)</b>	<b>3.24 (.204)</b>	<b>.13 (.040)</b>	<b>101.1° (38.4°)</b>					
	30° (16.7°)	24.8 (7.3)	1.71 (.108)	.04 (.012)	92.4° (33.6°)					
077	10° (5.6°)	58.7 (17.2)	12.11 (.764)	.98 (.299)	105.1° (40.6°)	1/20 (.037)	1550	1200 (.560)	1220 (6.198)	II
	<b>20° (11.1°)</b>	<b>48.4 (14.2)</b>	<b>4.99 (.315)</b>	<b>.18 (.055)</b>	<b>97.2° (36.2°)</b>					
	30° (16.7°)	38.1 (11.2)	2.62 (.165)	.05 (.015)	89.3° (31.8°)					
077*	10° (5.6°)	46.5 (13.6)	9.59 (.605)	.63 (.192)	110.0° (43.3°)	1/20 (.037)	1150	858 (.400)	894 (4.542)	II
	<b>20° (11.1°)</b>	<b>38.5 (11.3)</b>	<b>3.97 (.250)</b>	<b>.12 (.037)</b>	<b>101.2° (38.4°)</b>					
	30° (16.7°)	30.5 (8.9)	2.09 (.132)	.03 (.009)	92.7° (33.7°)					
104	10° (5.6°)	77.2 (22.6)	15.91 (1.004)	2.06 (.628)	106.6° (41.4°)	1/8 (.093)	1070	1528 (.713)	980 (4.978)	II
	<b>20° (11.1°)</b>	<b>68.3 (20.0)</b>	<b>7.03 (.443)</b>	<b>.44 (.134)</b>	<b>101.2° (38.4°)</b>					
	30° (16.7°)	59.3 (17.4)	4.08 (.257)	.16 (.049)	95.8° (35.4°)					
104*	10° (5.6°)	63.7 (18.7)	13.13 (.828)	1.43 (.436)	108.6° (42.6°)	1/8 (.093)	850	1208 (.564)	783 (3.978)	II
	<b>20° (11.1°)</b>	<b>56.5 (16.6)</b>	<b>5.82 (.367)</b>	<b>.31 (.095)</b>	<b>103.1° (39.5°)</b>					
	30° (16.7°)	49.2 (14.4)	3.38 (.213)	.11 (.034)	97.6° (36.4°)					
125	10° (5.6°)	94.9 (27.8)	19.55 (1.233)	3.04 (.927)	108.9° (42.7°)	1/6 (.124)	1100	1790 (.835)	1170 (5.944)	III
	<b>20° (11.1°)</b>	<b>83.7 (24.5)</b>	<b>8.63 (.544)</b>	<b>.65 (.198)</b>	<b>103.1° (39.5°)</b>					
	30° (16.7°)	72.5 (21.2)	4.98 (.314)	.23 (.070)	97.3° (36.3°)					

\*\* Performance based on 200°F (93°C) EWT, 20°F (11°C) TD, 60°F (16°C) EAT. Performance at 10°F (5.6°C) & 30°F (17°C) TD is also shown. For capacities at other conditions, use the correction multipliers in the tables on page 22.

\* Speed controller option is required for reduced ratings.

† Motor HP listed is applicable to standard motor type only. For explosion proof motor HP, see unit installation manual.

# Vertical Unit Heaters

## Hot Water Performance Data\*\* – Table 19

### STANDARD OUTPUT UNITS

Unit Size	Water Temp Drop °F (°C)	Output MBH (kW)	Flow Rate GPM (L/s)	Pressure Drop ft/water (m/water)	Final Air Temp °F (°C)	Motor HP† (kW)	Motor RPM	Nominal CFM (m³/s)	Outlet Velocity FPM (m/s)	Sound Rating
144	10° (5.6°)	117.6 (34.5)	24.24 (1.529)	4.32 (1.318)	108.8° (42.7°)	1/6 (.124)	1100	2220 (1.036)	1045 (5.309)	III
	<b>20° (11.1°)</b>	<b>105.2 (30.8)</b>	<b>10.84 (.684)</b>	<b>.96 (.293)</b>	<b>103.7° (39.8°)</b>					
	30° (16.7°)	92.8 (27.2)	6.38 (.402)	.36 (.110)	98.5° (36.9°)					
164	10° (5.6°)	132.4 (38.8)	27.29 (1.722)	3.67 (1.119)	106.6° (41.4°)	1/6 (.124)	1100	2620 (1.223)	1230 (6.248)	IV
	<b>20° (11.1°)</b>	<b>118.6 (34.7)</b>	<b>12.22 (.771)</b>	<b>.81 (.247)</b>	<b>101.7° (38.7°)</b>					
	30° (16.7°)	104.8 (30.7)	7.20 (.454)	.30 (.092)	96.9° (36.1°)					
200	10° (5.6°)	156.2 (45.8)	32.20 (2.031)	5.02 (1.531)	105.0° (40.6°)	1/4 (.186)	1100	3200 (1.493)	1495 (7.595)	III
	<b>20° (11.1°)</b>	<b>139.7 (40.9)</b>	<b>14.40 (.908)</b>	<b>1.11 (.339)</b>	<b>100.2° (37.9°)</b>					
	30° (16.7°)	123.2 (36.1)	8.47 (.534)	.41 (.125)	95.5° (35.3°)					
237	15° (8.3°)	188.9 (55.3)	25.95 (1.637)	3.92 (1.196)	101.8° (38.8°)	1/4 (.186)	1100	4162 (1.942)	1205 (6.121)	IV
	<b>20° (11.1°)</b>	<b>180.1 (52.8)</b>	<b>18.56 (1.171)</b>	<b>2.10 (.641)</b>	<b>99.9° (37.7°)</b>					
	30° (16.7°)	162.7 (47.7)	11.18 (.705)	.82 (.250)	96.0° (35.6°)					
285	15° (8.3°)	215.4 (63.1)	29.60 (1.867)	5.02 (1.531)	104.8° (40.4°)	1/2 (.373)	1100	4430 (2.067)	1275 (6.477)	IV
	<b>20° (11.1°)</b>	<b>205.4 (60.2)</b>	<b>21.17 (1.335)</b>	<b>2.68 (.817)</b>	<b>102.7° (39.3°)</b>					
	30° (16.7°)	185.3 (54.3)	12.73 (.803)	1.04 (.317)	98.5° (36.9°)					
317	15° (8.3°)	254.9 (74.7)	35.03 (2.210)	6.88 (2.098)	105.1° (40.6°)	3/4 (.559)	1140	5210 (2.431)	1500 (7.620)	IV
	<b>20° (11.1°)</b>	<b>242.9 (71.2)</b>	<b>25.03 (1.579)</b>	<b>3.67 (1.119)</b>	<b>103.0° (39.4°)</b>					
	30° (16.7°)	218.9 (64.1)	15.04 (.949)	1.42 (.433)	98.7° (37.1°)					
367	15° (8.3°)	294.7 (86.3)	40.49 (2.554)	6.60 (2.013)	104.2° (40.1°)	3/4 (.559)	1140	6140 (2.865)	1770 (8.992)	IV
	<b>20° (11.1°)</b>	<b>280.8 (82.3)</b>	<b>28.94 (1.826)</b>	<b>3.52 (1.074)</b>	<b>102.2° (39.0°)</b>					
	30° (16.7°)	253.1 (74.2)	17.39 (1.097)	1.36 (.415)	98.0° (36.7°)					
495	20° (11.1°)	<b>368.1 (107.9)</b>	<b>37.93 (2.393)</b>	<b>5.81 (1.772)</b>	<b>102.3° (39.1°)</b>	1-1/2 (1.119)	1160	8020 (3.743)	1640 (8.331)	IV
	30° (16.7°)	333.6 (97.7)	22.92 (1.446)	2.29 (.698)	98.3° (36.8°)					
	15° (8.3°)	451.2 (132.2)	62.00 (3.911)	8.78 (2.678)	104.0° (40.0°)					
585	20° (11.1°)	<b>431.1 (126.3)</b>	<b>44.43 (2.803)</b>	<b>4.72 (1.440)</b>	<b>102.0° (38.9°)</b>	1-1/2 (1.119)	1160	9450 (4.410)	1930 (9.804)	IV
	30° (16.7°)	391.0 (114.6)	26.86 (1.694)	1.86 (.567)	98.1° (36.7°)					
	20° (11.1°)	<b>519.4 (152.2)</b>	<b>53.52 (3.376)</b>	<b>5.29 (1.613)</b>	<b>103.5° (39.7°)</b>					
700	30° (16.7°)	470.9 (138.0)	32.35 (2.041)	2.08 (.634)	99.5° (37.5°)	3 (2.237)	1165	11,000 (5.133)	2250 (11.430)	IV

\*\* Performance based on 200°F (93°C) EWT, 20°F (11°C) TD, 60°F (16°C) EAT. Performance at 10°F (5.6°C) & 30°F (17°C) TD is also shown. For capacities at other conditions, use the correction multipliers in the tables on page 22.

† Motor HP listed is applicable to standard motor type only. For explosion proof motor HP, see unit installation manual.

# Vertical Unit Heaters

## Hot Water Performance Data\*\* — Table 20

### LOW OUTPUT UNITS

#### STANDARD VERTICAL UNITS WITH ALL AIR PORTS OPEN

Unit Size	Water Temp Drop °F (°C)	Output MBH (kW)	Flow Rate GPM (L/s)	Pressure Drop ft/water (m/water)	Final Air Temp °F (°C)	Motor HP† (kW)	Motor RPM	Nominal CFM (m³/s)	Outlet Velocity FPM (m/s)	Sound Rating
040L	10° (5.6°)	23.9 (7.0)	4.92 (.310)	.26 (.079)	92.9° (33.8°)	1/40 (.019)	1550	668 (.312)	950 (4.826)	I
	<b>20° (11.1°)</b>	<b>18.9 (5.5)</b>	<b>1.95 (.123)</b>	<b>.04 (.012)</b>	<b>86.1° (30.1°)</b>					
	30° (16.7°)	14.0 (4.1)	.96 (.061)	.01 (.003)	79.3° (26.3°)					
040L*	10° (5.6°)	16.7 (4.9)	3.45 (.218)	.13 (.040)	92.8° (33.8°)	1/40 (.019)	1150	470 (.219)	672 (3.414)	I
	<b>20° (11.1°)</b>	<b>13.5 (4.0)</b>	<b>1.39 (.088)</b>	<b>.02 (.006)</b>	<b>86.4° (30.2°)</b>					
	30° (16.7°)	10.0 (2.8)	.85 (.056)	.01 (.003)	79.3° (26.3°)					
062L	10° (5.6°)	41.5 (12.2)	8.56 (.540)	.80 (.244)	91.9° (33.3°)	1/20 (.037)	1550	1200 (.560)	1190 (6.045)	II
	<b>20° (11.1°)</b>	<b>34.2 (10.0)</b>	<b>3.53 (.223)</b>	<b>.15 (.046)</b>	<b>86.3° (30.2°)</b>					
	30° (16.7°)	27.0 (7.9)	1.85 (.117)	.04 (.012)	80.7° (27.1°)					
062L*	10° (5.6°)	32.4 (9.5)	6.68 (.421)	.50 (.153)	94.7° (34.8°)	1/20 (.037)	1150	862 (.402)	858 (4.359)	II
	<b>20° (11.1°)</b>	<b>26.9 (7.9)</b>	<b>2.77 (.175)</b>	<b>.09 (.027)</b>	<b>88.7° (31.5°)</b>					
	30° (16.7°)	21.3 (6.2)	1.46 (.092)	.03 (.009)	82.8° (28.2°)					
077L	10° (5.6°)	48.9 (14.3)	10.09 (.637)	.69 (.210)	93.2° (34.0°)	1/20 (.037)	1550	1360 (.635)	1350 (6.858)	II
	<b>20° (11.1°)</b>	<b>40.5 (11.9)</b>	<b>4.17 (.263)</b>	<b>.13 (.040)</b>	<b>87.4° (30.8°)</b>					
	30° (16.7°)	32.0 (9.4)	2.20 (.139)	.04 (.012)	81.7° (27.6°)					
077L*	10° (5.6°)	38.5 (11.3)	7.94 (.501)	.44 (.134)	95.7° (35.4°)	1/20 (.037)	1150	995 (.464)	992 (5.039)	II
	<b>20° (11.1°)</b>	<b>32.0 (9.4)</b>	<b>3.29 (.208)</b>	<b>.08 (.024)</b>	<b>89.6° (32.0°)</b>					
	30° (16.7°)	25.4 (7.4)	1.75 (.110)	.02 (.006)	83.5° (28.6°)					
104L	10° (5.6°)	63.7 (18.7)	13.13 (.828)	1.43 (.463)	93.5° (34.2°)	1/8 (.093)	1070	1752 (.818)	1050 (5.334)	II
	<b>20° (11.1°)</b>	<b>56.5 (16.6)</b>	<b>5.82 (.367)</b>	<b>.31 (.095)</b>	<b>89.7° (32.1°)</b>					
	30° (16.7°)	49.2 (14.4)	3.38 (.213)	.11 (.034)	85.9° (29.9°)					
104L*	10° (5.6°)	54.5 (16.0)	11.24 (.709)	1.06 (.323)	93.5° (34.2°)	1/8 (.093)	850	1499 (.700)	827 (4.201)	II
	<b>20° (11.1°)</b>	<b>48.5 (14.2)</b>	<b>4.99 (.315)</b>	<b>.23 (.070)</b>	<b>89.8° (32.1°)</b>					
	30° (16.7°)	42.4 (12.4)	2.91 (.184)	.08 (.024)	86.1° (30.1°)					
125	10° (5.6°)	83.7 (24.5)	17.24 (1.088)	2.40 (.732)	95.4° (35.2°)	1/6 (.124)	1100	2180 (1.017)	1390 (7.061)	III
	<b>20° (11.1°)</b>	<b>73.9 (21.7)</b>	<b>7.62 (.481)</b>	<b>.51 (.156)</b>	<b>91.3° (32.9°)</b>					
	30° (16.7°)	64.2 (18.8)	4.41 (.278)	.18 (.055)	87.1° (30.6°)					

\*\* Performance based on 200°F (93°C) EWT, 20°F (11°C) TD, 60°F (16°C) EAT. Performance at 10°F (5.6°C) & 30°F (17°C) TD is also shown.

For capacities at other conditions, use the correction multipliers in the tables on page 22.

\* Speed controller option is required for reduced ratings.

† Motor HP listed is applicable to standard motor type only. For explosion proof motor HP, see unit installation manual.

# Vertical Unit Heaters

## Hot Water Performance Data\*\* – Table 21

### LOW OUTPUT UNITS

#### STANDARD VERTICAL UNITS WITH ALL AIR PORTS OPEN

Unit Size	Water Temp Drop °F (°C)	Output MBH (kW)	Flow Rate GPM (L/s)	Pressure Drop ft/water (m/water)	Final Air Temp °F (°C)	Motor HP† (kW)	Motor RPM	Nominal CFM (m³/s)	Outlet Velocity FPM (m/s)	Sound Rating
144L	10° (5.6°)	95.4 (28.0)	19.66 (1.240)	2.92 (.891)	97.3° (36.3)	1/6 (.124)	1100	2360 (1.101)	1080 (5.486)	III
	<b>20° (11.1°)</b>	<b>85.5 (25.1)</b>	<b>8.81 (.556)</b>	<b>.65 (.198)</b>	<b>93.4° (34.1)</b>					
	30° (16.7°)	75.6 (22.2)	5.20 (.328)	.24 (.073)	89.5° (31.9)					
164L	10° (5.6°)	112.3 (32.9)	23.15 (1.460)	2.70 (.824)	95.4° (35.2)	1/6 (.124)	1100	2920 (1.363)	1340 (6.807)	IV
	<b>20° (11.1°)</b>	<b>100.7 (29.5)</b>	<b>10.38 (.655)</b>	<b>.60 (.183)</b>	<b>91.8° (33.2)</b>					
	30° (16.7°)	89.2 (26.1)	6.13 (.387)	.22 (.067)	88.1° (31.2)					
200L	10° (5.6°)	135.8 (39.8)	27.98 (1.765)	3.85 (1.174)	96.9° (36.1)	1/4 (.186)	1100	3390 (1.582)	1560 (7.925)	III
	<b>20° (11.1°)</b>	<b>121.8 (35.7)</b>	<b>12.52 (.790)</b>	<b>.85 (.259)</b>	<b>93.0° (33.9)</b>					
	30° (16.7°)	107.3 (31.4)	7.37 (.465)	.32 (.098)	89.2° (31.8)					
237L	10° (5.6°)	168.5 (49.4)	34.72 (2.190)	6.75 (2.059)	94.5° (34.7)	1/4 (.186)	1100	4507 (2.103)	1270 (6.452)	IV
	<b>20° (11.1°)</b>	<b>153.8 (45.1)</b>	<b>15.85 (1.000)</b>	<b>1.56 (.476)</b>	<b>91.4° (33.0)</b>					
	30° (16.7°)	139.1 (40.8)	9.56 (.603)	.61 (.186)	88.4° (31.3)					
285L	10° (5.6°)	188.9 (55.3)	25.95 (1.637)	3.92 (1.196)	94.5° (34.7)	1/2 (.373)	1100	5040 (2.352)	1420 (7.214)	IV
	<b>20° (11.1°)</b>	<b>180.1 (52.8)</b>	<b>18.56 (1.171)</b>	<b>2.10 (.641)</b>	<b>92.9° (33.8)</b>					
	30° (16.7°)	162.7 (47.7)	11.18 (.705)	.82 (.250)	89.7° (32.1)					
317L	10° (5.6°)	220.9 (64.7)	30.35 (1.915)	5.26 (1.604)	95.7° (35.4)	3/4 (.559)	1140	5700 (2.660)	1610 (8.179)	IV
	<b>20° (11.1°)</b>	<b>210.6 (61.7)</b>	<b>21.70 (1.369)</b>	<b>2.81 (.857)</b>	<b>94.1° (34.5)</b>					
	30° (16.7°)	189.9 (55.6)	13.05 (.823)	1.09 (.332)	90.7° (32.6)					
367L	10° (5.6°)	260.7 (76.4)	35.82 (2.260)	5.24 (1.598)	96.4° (35.8)	3/4 (.559)	1140	6600 (3.080)	1870 (9.500)	IV
	<b>20° (11.1°)</b>	<b>248.5 (72.8)</b>	<b>25.61 (1.616)</b>	<b>2.80 (.854)</b>	<b>94.7° (34.8)</b>					
	30° (16.7°)	224.2 (65.7)	15.40 (.971)	1.09 (.332)	91.3° (32.9)					
495L	10° (5.6°)	394.4 (115.6)	54.19 (3.418)	6.83 (2.083)	95.3° (35.2)	1-1/2 (1.119)	1160	9380 (4.377)	1860 (9.449)	IV
	<b>20° (11.1°)</b>	<b>377.0 (110.5)</b>	<b>38.85 (2.451)</b>	<b>3.68 (1.122)</b>	<b>93.7° (34.3)</b>					
	30° (16.7°)	342.2 (100.3)	23.51 (1.483)	1.45 (.442)	90.6° (32.6)					
585L	10° (5.6°)	394.4 (115.6)	54.19 (3.418)	6.83 (2.083)	95.3° (35.2)	1-1/2 (1.119)	1160	10,300 (4.807)	2060 (10.465)	IV
	<b>20° (11.1°)</b>	<b>377.0 (110.5)</b>	<b>38.85 (2.451)</b>	<b>3.68 (1.122)</b>	<b>93.7° (34.3)</b>					
	30° (16.7°)	342.2 (100.3)	23.51 (1.483)	1.45 (.442)	90.6° (32.6)					
700L	10° (5.6°)	394.4 (115.6)	54.19 (3.418)	6.83 (2.083)	95.3° (35.2)	3 (2.237)	1165	11,900 (5.553)	2380 (12.090)	IV
	<b>20° (11.1°)</b>	<b>453.7 (132.9)</b>	<b>46.76 (2.950)</b>	<b>4.11 (1.254)</b>	<b>95.1° (35.1)</b>					
	30° (16.7°)	411.7 (120.6)	28.28 (1.784)	1.62 (.494)	91.9° (33.3)					

\*\* Performance based on 200°F (93°C) EWT, 20°F (11°C) TD, 60°F (16°C) EAT. Performance at 10°F (5.6°C) & 30°F (17°C) TD is also shown.

For capacities at other conditions, use the correction multipliers in the tables on page 22.

† Motor HP listed is applicable to standard motor type only. For explosion proof motor HP, see unit installation manual.

# Vertical Unit Heaters Hot Water Calculations and Correction Factors

**EXAMPLE: –**

UNIT SIZE: \_\_\_\_\_ 40  
 Entering Water Temp. \_\_\_\_\_ 160°F  
 Entering Air Temp. \_\_\_\_\_ 40°F  
 Water Temperature Drop \_\_\_\_\_ 10°F

<b>I. CAPACITY @ 20°F TD:</b> A. For 200°F EWT, 60°F EAT	Read output directly from Tables 18-21, 22,700 BTU/HR (Ref., Std. Unit Size 40, p. 18)	
B. For EWT and/or EAT above or below Standard	Multiply output from Tables 18-21 by factor from Table 22 (below)	22,700 x .878 = 19,931 BTU/HR
<b>II. CAPACITY AT OTHER TD's</b> A. For TD's from 5 to 60°F	Multiply output obtained in IA or IB (above) by appropriate factor from Table 23 (below)	IA - 22,700 x 1.15 = 26,105 BTU/HR – OR – IB - 19,931 x 1.15 = 22,921 BTU/HR
<b>III. GPM AT OTHER TD's</b> A. For TD's from 5 to 60°F	Multiply GPM of unit for 20°F TD, from Table 18 by appropriate factor from Table 23 (below)	2.34 x 2.30 = 5.38 GPM (Applies only to units with Std 200°F EWT, 60°F EAT) For all others calculate using formula – $GPM = \frac{BTU}{500 \times TD}$
<b>IV. PRESSURE LOSS AT OTHER TD's</b> A. For TD's from 5 to 60°F	Multiply PD of unit for 20°F TD, from Tables 18-21 by appropriate factor from Table 23 (below)	.06 x 5.00 = .30 Ft. H <sub>2</sub> O

**Table 22 – HOT WATER CONVERSION FACTORS BASED ON 200°F (93°C) ENTERING WATER 60°F (16°C) ENTERING AIR 20°F (11°C) TEMPERATURE DROP**

ENTERING AIR TEMPERATURE °F (°C)	ENTERING WATER TEMPERATURE – 20°F (11°C) WATER TEMPERATURE DROP										
	100° (38°)	120° (49°)	140° (60°)	160° (71°)	180° (82°)	200° (93°)	220° (104°)	240° (116°)	260° (127°)	280° (138°)	300° (149°)
30° (-1)	0.518	0.666	0.814	0.963	1.120	1.268	1.408	1.555	1.702	1.850	1.997
40° (4)	0.439	0.585	0.731	0.878	1.025	1.172	1.317	1.464	1.609	1.755	1.908
50° (10)	0.361	0.506	0.651	0.796	0.941	1.085	1.231	1.375	1.518	1.663	1.824
60° (16)	0.286	0.429	0.571	0.715	0.857	1.000	1.143	1.286	1.429	1.571	1.717
70° (21)	0.212	0.353	0.494	0.636	0.777	0.918	1.060	1.201	1.342	1.483	1.630
80° (27)	0.140	0.279	0.419	0.558	0.698	0.837	0.977	1.117	1.257	1.397	1.545
90° (32)	0.069	0.207	0.345	0.483	0.621	0.759	0.897	1.035	1.173	1.311	1.462
100° (38)	0	0.137	0.273	0.409	0.546	0.682	0.818	0.955	1.094	1.230	1.371

To obtain the BTU capacity for conditions other than those in the basic capacity tables, multiply the basic rating (200°F (93°C) entering water, 60°F (16°C) entering air,) by the proper constant from the above tables.

**Table 23 – HOT WATER BTU, GPM AND PRESSURE LOSS FACTORS BASED ON STANDARD CONDITIONS OF 200°F (93°C) ENTERING WATER 60°F (16°C) ENTERING AIR & 20°F (11°C) WATER DROP**

USE FACTORS FROM THIS TABLE TO OBTAIN APPROXIMATE RESULTS	TEMPERATURE DROP °F (°C)								
	5 (3)	10 (6)	15 (8)	20 (11)	25 (14)	30 (17)	40 (22)	50 (28)	60 (33)
To obtain BTU for other Water Temperature Drops, multiply basic BTU rating by applicable Factor.	1.25	1.15	1.08	1.00	.94	.90	.83	.76	.72
To obtain GPM for other Water Temperature Drops, multiply basic GPM rating by applicable Factor.*	5.00	2.30	1.44	1.00	.74	.59	.40	.30	.24
To obtain Pressure Loss Feet of Water for other temperature Drops, multiply Basic loss at 20°F drop by Factor.	10.00	5.00	2.00	1.00	.60	.40	.20	.13	.07

**Table 24 – MINIMUM WATER FLOW – GPM**

UNIT SIZE	40	62	77	104	144	164	200	237	317	367
MIN.	.55	.55	.55	.55	.82	.82	1.10	1.10	1.10	1.10
GPM (L/s)	(.035)	(.035)	(.035)	(.035)	(.052)	(.052)	(.069)	(.069)	(.069)	(.069)

**\*Table 25 – HEATING CAPACITY FACTORS FOR VARIOUS RATES OF WATER FLOW**

% of Rated Water Flow	25%	50%	75%	100%	125%	150%	175%
Heating Capacity Factor	.80	.89	.96	1.00	1.04	1.07	1.10

# Vertical Unit Heaters Dimensional Data

Figure 6

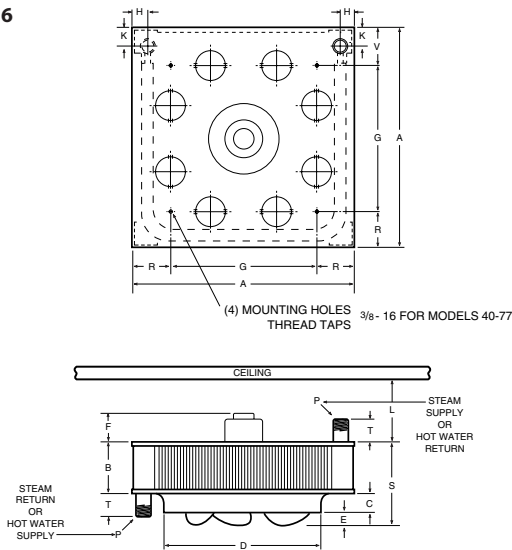

Figure 7

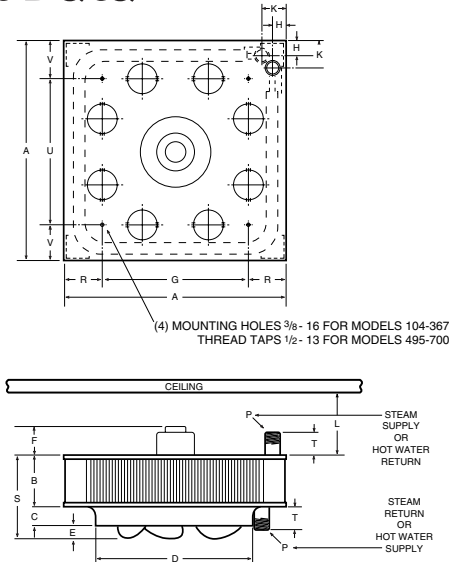

Table 25 - FIGURE 6 - ROUGHING IN DIMENSIONAL DATA - MODEL SIZE 40-77

Unit Capacity (MBH)	Fan Dia. (inches (mm))	A (inches (mm))	B (inches (mm))	C (inches (mm))	D (inches (mm))	E (inches (mm))	F (inches (mm))	G (inches (mm))	H (inches (mm))	K (inches (mm))	L Min (inches (mm))	P NPT (inches (mm))	R (inches (mm))	S (inches (mm))	T (inches (mm))	U (inches (mm))	V (inches (mm))	Approx. Ship Wt. lbs (kg)
40	11-1/4 (286)	18-1/4 (464)	4-5/8 (117)	1-1/4 (32)	11-3/4 (298)	3/4 (19)	4 (102)	11 (279)	1-3/8 (35)	1-7/8 (48)	7 (178)	1-1/2 (38)	3-5/8 (92)	6-5/8 (168)	2-3/4 (70)	11 (279)	3-5/8 (92)	32 (15)
62	13-1/2 (343)	21-1/4 (540)	4-5/8 (117)	1-5/8 (41)	14 (356)	1 (25)	4 (102)	14 (356)	1-3/8 (35)	1-7/8 (48)	7 (178)	1-1/2 (38)	3-5/8 (92)	7-1/8 (181)	2-3/4 (70)	14 (356)	3-5/8 (92)	40 (18)
77	13-1/2 (343)	21-1/4 (540)	6-1/8 (156)	1-5/8 (41)	14 (356)	1 (25)	3 (76)	14 (356)	1-3/8 (35)	1-7/8 (48)	7 (178)	1-1/2 (38)	3-5/8 (92)	8-5/8 (219)	2-3/4 (70)	14 (356)	3-5/8 (92)	43 (20)

Table 26 - FIGURE 7 - ROUGHING IN DIMENSIONAL DATA - MODEL SIZE 104-700

Unit Capacity (MBH)	Fan Dia. (inches (mm))	A (inches (mm))	B (inches (mm))	C (inches (mm))	D (inches (mm))	E (inches (mm))	F (inches (mm))	G (inches (mm))	H (inches (mm))	K (inches (mm))	L Min (inches (mm))	P NPT (inches (mm))	R (inches (mm))	S (inches (mm))	T (inches (mm))	U (inches (mm))	V (inches (mm))	Approx. Ship Wt. lbs (kg)
104	16-3/4 (425)	25-1/4 (641)	6-1/8 (156)	2 (51)	17-1/2 (445)	1-1/8 (29)	3 (76)	17 (432)	1-3/8 (35)	2-3/4 (70)	7 (178)	1-1/2 (38)	4-1/8 (105)	9-1/8 (232)	2-3/4 (70)	17 (432)	4-1/8 (105)	63 (29)
125	16-3/4 (425)	25-1/4 (641)	6-1/8 (156)	2 (51)	17-1/2 (445)	1-3/4 (44)	3 (76)	17 (432)	1-3/8 (35)	2-3/4 (70)	7 (178)	1-1/2 (38)	4-1/8 (105)	9-3/4 (248)	2-3/4 (70)	17 (432)	4-1/8 (105)	64 (29)
144	19-3/4 (502)	29-1/2 (749)	6-1/8 (156)	2-3/8 (60)	20-5/8 (524)	1-1/4 (32)	4 (102)	20-1/2 (521)	1-3/4 (44)	3-1/2 (89)	7 (178)	2 (51)	4-1/2 (114)	9-5/8 (244)	2-3/4 (70)	20-1/2 (521)	4-1/2 (114)	80 (36)
164	19-3/4 (502)	29-1/2 (749)	6-1/8 (156)	2-3/8 (60)	20-5/8 (524)	1-3/4 (44)	4 (102)	20-1/2 (521)	1-3/4 (44)	3-1/2 (89)	7 (178)	2 (51)	4-1/2 (114)	10-1/8 (257)	2-3/4 (70)	20-1/2 (521)	4-1/2 (114)	80 (36)
200	19-3/4 (502)	29-1/2 (749)	7-5/8 (194)	2-3/8 (60)	20-5/8 (524)	2 (51)	4 (102)	20-1/2 (521)	1-3/4 (44)	3-1/2 (89)	7 (178)	2 (51)	4-1/2 (114)	12 (305)	2-3/4 (70)	20-1/2 (521)	4-1/2 (114)	86 (39)
237	25-1/4 (641)	37-1/2 (953)	7-5/8 (194)	3 (76)	26-3/8 (670)	1 (25)	3-1/2 (89)	28 (711)	1-3/4 (44)	3-1/2 (89)	7 (178)	2 (51)	4-3/4 (121)	11-5/8 (295)	2-3/4 (70)	18 (457)	9-3/4 (248)	134 (61)
285	25-1/4 (641)	37-1/2 (953)	7-5/8 (194)	3 (76)	26-3/8 (670)	1-1/4 (32)	3-1/2 (89)	28 (711)	1-3/4 (44)	3-1/2 (89)	7 (178)	2 (51)	4-3/4 (121)	11-3/4 (298)	2-3/4 (70)	18 (457)	9-3/4 (248)	139 (63)
317	25-1/4 (641)	37-1/2 (953)	7-5/8 (194)	3 (76)	26-3/8 (670)	2-1/8 (54)	4 (102)	28 (711)	1-3/4 (44)	3-1/2 (89)	7 (178)	2 (51)	4-3/4 (121)	12-3/4 (324)	2-3/4 (70)	18 (457)	9-3/4 (248)	139 (63)
367	25-1/4 (641)	37-1/2 (953)	9-1/8 (232)	3 (76)	26-3/8 (670)	2 (51)	3-1/2 (89)	28 (711)	1-3/4 (44)	3-1/2 (89)	7 (178)	2 (51)	4-3/4 (121)	14-1/8 (359)	2-3/4 (70)	18 (457)	9-3/4 (248)	146 (66)
495	30-1/2 (775)	42 (1067)	9-1/8 (232)	3-1/2 (89)	31-1/4 (794)	1-5/8 (41)	3 (76)	30 (762)	2-1/4 (57)	4-1/4 (108)	7 (178)	2-1/2 (64)	6 (152)	14-1/4 (362)	3 (76)	30 (762)	6 (152)	294 (133)
585	30-1/2 (775)	42 (1067)	12-1/8 (308)	3-1/2 (89)	31-1/4 (794)	2-1/8 (54)	3 (76)	30 (762)	2-1/4 (57)	4-1/4 (108)	7 (178)	2-1/2 (64)	6 (152)	17-3/4 (451)	3 (76)	30 (762)	6 (152)	307 (139)
700	30-1/2 (775)	42 (1067)	13-5/8 (346)	3-1/2 (89)	31-1/4 (794)	3 (76)	4 (102)	30 (762)	2-1/4 (57)	4-1/4 (108)	7 (178)	2-1/2 (64)	6 (152)	20-1/4 (514)	3 (76)	30 (762)	6 (152)	366 (166)

Table 27 - FIGURE 8  
LOUVER CONE DIFFUSER ROUGHING-IN DIMENSIONS - in. (mm)

Unit Size	A	B	C	D	Number of Louvers
40	16-1/2 (419)	14-1/4 (362)	6-1/2 (165)	2-5/8 (67)	8
62 & 77	20-1/4 (514)	17-1/8 (435)	8-1/2 (216)	3-1/8 (79)	8
104 & 125	24-1/4 (616)	21-1/8 (537)	9-3/4 (248)	3-15/16 (100)	8
144, 164 & 200	28-3/8 (721)	24-3/4 (629)	11-1/2 (292)	4-5/8 (117)	8
237, 285, 317 & 367	35-1/2 (902)	31-1/2 (800)	13-3/4 (349)	4-5/8 (117)	12
495, 585, 700	41-1/2 (1054)	37-1/4 (946)	17-1/2 (445)	4-3/4 (121)	12

Figure 8

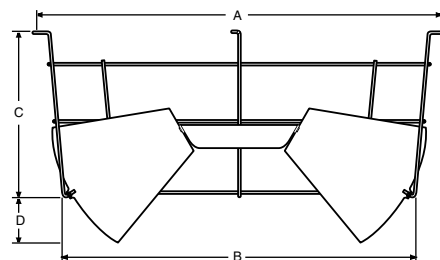

# Vertical Unit Heaters Mounting Heights & Throws, Technical Data – Table 28

## MAXIMUM MOUNTING HEIGHT IN FEET FOR VERTICAL UNIT HEATERS WITH AND WITHOUT LOUVER CONE DIFFUSER

Unit Size	2 (0.61) 5 (1.52) 10 (3.05) 50 (15.24) 75 (22.86)					Unit Size	2 (0.61) 5 (1.52) 10 (3.05) 50 (15.24) 75 (22.86)					Unit Size	2 (0.61) 5 (1.52) 10 (3.05) 50 (15.24) 75 (22.86)					Unit Size	2 (0.61) 5 (1.52) 10 (3.05) 50 (15.24) 75 (22.86)				
	Steam Pressure PSI (kPa)						Steam Pressure PSI (kPa)						Steam Pressure PSI (kPa)						Steam Pressure PSI (kPa)				
40	10.5 (3.2)	10.0 (3.0)	10.0 (3.0)	9.0 (2.7)	8.0 (2.4)	77L	18.0 (5.5)	17.5 (5.3)	17.5 (5.3)	15.0 (4.6)	14.0 (4.3)	164	18.0 (5.5)	17.5 (5.3)	17.0 (5.2)	14.5 (4.4)	14.0 (4.3)	317L	29.0 (8.8)	28.5 (8.7)	28.0 (8.5)	25.0 (7.6)	24.0 (7.3)
	<b>12.5 (3.8)</b>	<b>12.0 (3.7)</b>	<b>12.0 (3.7)</b>	<b>11.0 (3.4)</b>	<b>10.0 (3.0)</b>		<b>22.0 (6.7)</b>	<b>21.0 (6.4)</b>	<b>21.0 (6.4)</b>	<b>19.0 (5.8)</b>	<b>18.0 (5.5)</b>		<b>22.5 (6.9)</b>	<b>22.0 (6.7)</b>	<b>21.5 (6.6)</b>	<b>19.0 (5.8)</b>	<b>18.0 (5.5)</b>		<b>36.0 (11.0)</b>	<b>35.0 (10.7)</b>	<b>34.0 (10.4)</b>	<b>30.0 (9.1)</b>	<b>29.0 (8.8)</b>
40*	7.5 (2.3)	7.5 (2.3)	7.5 (2.3)	7.5 (2.3)	7.5 (2.3)	77L*	13.0 (4.0)	12.5 (3.8)	12.0 (3.7)	11.0 (3.4)	10.5 (3.2)	164L	22.0 (6.7)	21.5 (6.6)	21.0 (6.4)	18.5 (5.6)	17.5 (5.3)	367	28.5 (8.7)	28.0 (8.5)	27.5 (8.4)	24.0 (7.3)	23.0 (7.0)
	<b>9.0 (2.7)</b>	<b>8.5 (2.6)</b>	<b>8.5 (2.6)</b>	<b>7.5 (2.3)</b>	<b>7.5 (2.3)</b>		<b>17.0 (5.2)</b>	<b>16.5 (5.0)</b>	<b>16.0 (4.9)</b>	<b>14.0 (4.3)</b>	<b>13.5 (4.1)</b>		<b>27.5 (8.4)</b>	<b>27.0 (8.2)</b>	<b>26.5 (8.1)</b>	<b>23.5 (7.2)</b>	<b>22.5 (6.9)</b>		<b>35.5 (10.8)</b>	<b>35.0 (10.7)</b>	<b>34.0 (10.4)</b>	<b>30.0 (9.1)</b>	<b>29.0 (8.8)</b>
40L	12.5 (3.8)	12.0 (3.7)	12.0 (3.7)	10.5 (3.2)	9.5 (2.9)	104	14.0 (4.3)	13.5 (4.1)	13.0 (4.0)	11.5 (3.5)	11.0 (3.4)	200	22.0 (6.7)	21.5 (6.6)	21.0 (6.4)	18.5 (5.6)	17.5 (5.3)	367L	32.5 (9.9)	31.5 (9.6)	30.5 (9.3)	27.5 (8.4)	26.5 (8.1)
	<b>14.5 (4.4)</b>	<b>14.0 (4.3)</b>	<b>13.5 (4.1)</b>	<b>12.0 (3.7)</b>	<b>11.5 (3.5)</b>		<b>17.0 (5.2)</b>	<b>16.5 (5.0)</b>	<b>16.0 (4.9)</b>	<b>14.0 (4.3)</b>	<b>13.5 (4.1)</b>		<b>27.5 (8.4)</b>	<b>27.0 (8.2)</b>	<b>26.5 (8.1)</b>	<b>24.0 (7.3)</b>	<b>23.0 (7.0)</b>		<b>41.0 (12.5)</b>	<b>40.0 (12.2)</b>	<b>39.0 (11.9)</b>	<b>35.0 (10.7)</b>	<b>33.5 (10.2)</b>
40L*	9.0 (2.7)	8.5 (2.6)	8.5 (2.6)	7.5 (2.3)	7.5 (2.3)	104*	11.0 (3.4)	10.5 (3.2)	10.5 (3.2)	9.5 (2.9)	9.0 (2.7)	200L	25.5 (7.8)	25.0 (7.6)	24.5 (7.5)	22.0 (6.7)	21.0 (6.4)	495	29.5 (9.0)	29.0 (8.8)	28.5 (8.7)	25.0 (7.6)	24.0 (7.3)
	<b>10.5 (3.2)</b>	<b>10.0 (3.0)</b>	<b>10.0 (3.0)</b>	<b>9.0 (2.7)</b>	<b>8.5 (2.6)</b>		<b>13.5 (4.1)</b>	<b>13.0 (4.0)</b>	<b>13.0 (4.0)</b>	<b>12.0 (3.7)</b>	<b>11.5 (3.5)</b>		<b>31.5 (9.6)</b>	<b>31.0 (9.4)</b>	<b>30.5 (9.3)</b>	<b>27.0 (8.2)</b>	<b>26.0 (7.9)</b>		<b>36.5 (11.1)</b>	<b>36.0 (11.0)</b>	<b>35.5 (10.8)</b>	<b>32.0 (9.8)</b>	<b>30.5 (9.3)</b>
62	12.0 (3.7)	11.5 (3.5)	11.5 (3.5)	10.0 (3.0)	9.5 (2.9)	104L	17.5 (5.3)	17.0 (5.2)	16.5 (5.0)	15.0 (4.6)	14.5 (4.4)	237	20.0 (6.1)	19.5 (5.9)	19.0 (5.8)	17.0 (5.2)	16.0 (4.9)	495L	35.0 (10.7)	34.0 (10.4)	33.0 (10.1)	29.0 (8.8)	28.0 (8.5)
	<b>14.5 (4.4)</b>	<b>14.0 (4.3)</b>	<b>14.0 (4.3)</b>	<b>12.0 (3.7)</b>	<b>11.5 (3.5)</b>		<b>21.5 (6.6)</b>	<b>21.0 (6.4)</b>	<b>20.5 (6.2)</b>	<b>18.5 (5.6)</b>	<b>17.5 (5.3)</b>		<b>25.0 (7.6)</b>	<b>24.0 (7.3)</b>	<b>23.5 (7.2)</b>	<b>20.5 (6.2)</b>	<b>19.5 (5.9)</b>		<b>43.5 (13.3)</b>	<b>42.5 (13.0)</b>	<b>41.5 (12.6)</b>	<b>35.0 (10.7)</b>	<b>34.0 (10.4)</b>
62*	9.5 (2.9)	9.0 (2.7)	9.0 (2.7)	8.0 (2.4)	8.0 (2.4)	104L*	15.0 (4.6)	14.5 (4.4)	14.5 (4.4)	13.0 (4.0)	12.5 (3.8)	237L	24.0 (7.3)	23.5 (7.2)	23.0 (7.0)	20.0 (6.1)	19.0 (5.8)	585	34.0 (10.4)	33.0 (10.1)	32.0 (9.8)	28.0 (8.5)	27.0 (8.2)
	<b>11.5 (3.5)</b>	<b>11.0 (3.4)</b>	<b>11.0 (3.4)</b>	<b>9.5 (2.9)</b>	<b>9.0 (2.7)</b>		<b>18.5 (5.6)</b>	<b>18.0 (5.5)</b>	<b>18.0 (5.5)</b>	<b>16.0 (4.9)</b>	<b>15.0 (4.6)</b>		<b>29.5 (9.0)</b>	<b>28.5 (8.7)</b>	<b>28.0 (8.5)</b>	<b>24.5 (7.5)</b>	<b>23.5 (7.2)</b>		<b>42.5 (13.0)</b>	<b>41.5 (12.6)</b>	<b>40.5 (12.3)</b>	<b>36.0 (11.0)</b>	<b>34.5 (10.5)</b>
62L	15.0 (4.6)	14.5 (4.4)	14.5 (4.4)	12.5 (3.8)	12.0 (3.7)	125	16.0 (4.9)	15.5 (4.7)	15.5 (4.7)	14.0 (4.3)	13.5 (4.1)	285	21.0 (6.4)	20.5 (6.2)	20.0 (6.1)	17.5 (5.3)	17.0 (5.2)	585L	37.0 (11.3)	36.0 (11.0)	35.0 (10.7)	31.0 (9.4)	30.0 (9.1)
	<b>19.0 (5.8)</b>	<b>18.5 (5.6)</b>	<b>18.5 (5.6)</b>	<b>16.5 (5.0)</b>	<b>16.0 (4.9)</b>		<b>19.5 (5.9)</b>	<b>19.0 (5.8)</b>	<b>18.5 (5.6)</b>	<b>17.0 (5.2)</b>	<b>16.0 (4.9)</b>		<b>26.0 (7.9)</b>	<b>25.5 (7.8)</b>	<b>25.0 (7.6)</b>	<b>22.0 (6.7)</b>	<b>21.0 (6.4)</b>		<b>46.5 (14.2)</b>	<b>45.5 (13.9)</b>	<b>44.5 (13.6)</b>	<b>39.0 (11.9)</b>	<b>37.0 (11.3)</b>
62L*	11.5 (3.5)	11.0 (3.4)	11.0 (3.4)	9.5 (2.9)	9.0 (2.7)	125L	21.0 (6.4)	20.5 (6.2)	20.0 (6.1)	17.5 (5.3)	17.0 (5.2)	285L	25.5 (7.8)	25.0 (7.6)	24.5 (7.5)	21.0 (6.4)	20.0 (6.1)	700	38.5 (11.7)	37.5 (11.4)	36.5 (11.1)	32.0 (9.8)	30.5 (9.3)
	<b>14.0 (4.3)</b>	<b>13.5 (4.1)</b>	<b>13.5 (4.1)</b>	<b>12.0 (3.7)</b>	<b>11.5 (3.5)</b>		<b>26.0 (7.9)</b>	<b>25.5 (7.8)</b>	<b>25.0 (7.6)</b>	<b>22.5 (6.9)</b>	<b>21.5 (6.6)</b>		<b>32.0 (9.8)</b>	<b>31.0 (9.4)</b>	<b>30.0 (9.1)</b>	<b>26.0 (7.9)</b>	<b>25.0 (7.6)</b>		<b>48.0 (14.6)</b>	<b>47.0 (14.3)</b>	<b>46.0 (14.0)</b>	<b>40.0 (12.2)</b>	<b>39.0 (11.9)</b>
77	15.0 (4.6)	14.5 (4.4)	14.0 (4.3)	12.0 (3.7)	11.5 (3.5)	144	15.5 (4.7)	15.0 (4.6)	14.5 (4.4)	13.0 (4.0)	12.0 (3.7)	317	24.0 (7.3)	23.0 (7.0)	22.0 (6.7)	20.0 (6.1)	19.0 (5.8)	700L	42.5 (13.0)	41.5 (12.6)	40.5 (12.3)	35.0 (10.7)	33.5 (10.2)
	<b>18.5 (5.6)</b>	<b>18.0 (5.5)</b>	<b>17.5 (5.3)</b>	<b>15.5 (4.7)</b>	<b>15.0 (4.6)</b>		<b>19.0 (5.8)</b>	<b>18.5 (5.6)</b>	<b>18.0 (5.5)</b>	<b>16.0 (4.9)</b>	<b>15.5 (4.7)</b>		<b>30.0 (9.1)</b>	<b>29.0 (8.8)</b>	<b>28.0 (8.5)</b>	<b>25.0 (7.6)</b>	<b>24.0 (7.3)</b>		<b>53.0 (16.2)</b>	<b>52.0 (15.8)</b>	<b>51.0 (15.5)</b>	<b>44.0 (13.4)</b>	<b>42.0 (12.8)</b>
77*	11.0 (3.4)	10.5 (3.2)	10.5 (3.2)	9.0 (2.7)	8.5 (2.6)	144L	18.0 (5.5)	17.5 (5.3)	17.5 (5.3)	15.0 (4.6)	14.0 (4.3)		18.0 (5.5)	17.5 (5.3)	17.5 (5.3)	15.0 (4.6)	14.0 (4.3)		22.5 (6.9)	22.0 (6.7)	21.5 (6.6)	18.5 (5.6)	18.0 (5.5)
	<b>13.5 (4.1)</b>	<b>13.0 (4.0)</b>	<b>13.0 (4.0)</b>	<b>11.5 (3.5)</b>	<b>11.0 (3.4)</b>		<b>22.5 (6.9)</b>	<b>22.0 (6.7)</b>	<b>21.5 (6.6)</b>	<b>18.5 (5.6)</b>	<b>18.0 (5.5)</b>												

NOTES:

\* = Low Speed

L = Vertical low output model with all air ports open

Figures in bold face show maximum mounting height with louver cone diffusers set vertically.

To meet ETL and OSHA requirements, units mounted below 8 feet from floor must be equipped with an OSHA fan guard. Please see page 28 for ordering information.

Above table based on 60°F (16°C) entering air temperature. In providing for the use of diffusers, it must be remembered that adjustment of a LCD to deflect air toward horizontal immediately lowers the mounting height limit.

## MAXIMUM SPREAD

Unit Size:	40	62	77	104	125	144	164	200	237	285	317	367	495	585	700
Spread - ft. (m)	15 (4.6)	17 (5.2)	20 (6.1)	24 (7.3)	26 (7.9)	27 (8.2)	28 (8.5)	32 (9.8)	35 (10.7)	37 (11.3)	45 (13.7)	50 (15.2)	54 (16.5)	57 (17.4)	60 (18.3)

NOTE: The "spread" is the diameter of the comfort zone at floor level. Projected by the vertical unit without the louver cone diffuser. Based on two pounds steam pressure (13.8 kPa) and 60°F (16°C) entering air.

## TECHNICAL DATA

Propylene Glycol, when sizing equipment for systems that will utilize a Propylene Glycol solution consider the factors shown on page 8.

## Mounting Height Correction Factors

Water Temperature	°F	150	160	170	180	190	200
	(°C)	(66)	(71)	(77)	(82)	(88)	(93)
Steam Pressure	PSI	—	—	—	—	—	—
	(kPa)	—	—	—	—	—	—
Correction Factor		1.32	1.27	1.23	1.18	1.14	1.09

Water Temperature	°F	210	219	227	239	250	259
	(°C)	(99)	(104)	(108)	(115)	(121)	(126)
Steam Pressure	PSI	—	2	5	10	15	20
	(kPa)	—	(13.8)	(34.5)	(68.9)	(103.4)	(137.9)
Correction Factor		1.05	1.00	0.97	0.94	0.89	0.86

Water Temperature	°F	267	280	287	298	307	320
	(°C)	(131)	(138)	(142)	(148)	(153)	(160)
Steam Pressure	PSI	25	35	40	50	60	75
	(kPa)	(172.4)	(241.3)	(275.8)	(344.7)	(413.6)	(517.1)
Correction Factor		0.83	0.80	0.76	0.73	0.70	0.69

# Vertical Unit Heaters Motor Characteristics

**Table 29 - TOTALLY ENCLOSED MOTOR TYPE**

Unit Size	AMP	MCA	MOP	HP	RPM
<b>115/1/60 [SV=1]</b>					
40	1.23**	1.6	2.8	1/40*	1550
62	2.1**	2.6	4.7	1/20*	1550
77					
104	1.2**	1.5	2.7	1/8*	1070
125	2.3**	2.9	5.2	1/6	1100
144					
164					
200	3.6**	4.5	8.1	1/4	1100
237	3.6**	4.5	8.1	1/4	1100
285	5.4**	6.8	12.2	1/2	1100
<b>208-230/460/3/60 [SV=4, 5 or 6]</b>					
40	0.98-1.1/0.55†	1.2-1.4/0.7	2.2-2.5/1.2	1/6	1140
62	0.98-1.1/0.55†	1.2-1.4/0.7	2.2-2.5/1.2	1/6	1140
77					
104	0.98-1.1/0.55†	1.2-1.4/0.7	2.2-2.5/1.2	1/6	1140
125	0.98-1.1/0.55†	1.2-1.4/0.7	2.2-2.5/1.2	1/6	1140
144					
164					
200	1.2-1.4/0.7†	1.5-1.8/0.9	2.7-3.2/1.6	1/4	1140
237	1.2-1.4/0.7†	1.5-1.8/0.9	2.7-3.2/1.6	1/4	1140
285	1.8-2.0/1.0†	2.3-2.5/1.3	4.1-4.5/2.3	1/2	1140
317	3.1-3.2/1.6†	3.9-4.0/2.0	7.0-7.2/3.6	3/4	1140
367					
495	5.0-4.4/2.2†	6.3-5.5/2.8	11.9-11.3/5.6	1-1/2	1160
585	9.6-8.2/4.1†	12.0-10.3/5.1	22.3-22.1/11.0	3	1165
700					

NOTE 1: All motors are constant speed and operate at top speed as indicated in motor data. Models through 1/8 HP can be run at reduced speed with addition of optional variable speed switch. This switch is factory-calibrated for low and high speed ratings, with intermediate speeds infinitely controllable. Sizes 164 through 700 operate at constant speed as indicated in motor data.

NOTE 2: Stated draw is full load amps (FLA). AMP draw varies by motor manufacturer ± .2 AMPS.

**Table 30 - EXPLOSION PROOF WITH THERMAL OVERLOAD MOTOR TYPE**

Unit Size	AMP	MCA	MOP	HP	RPM
<b>115/1/60 [SV=1]</b>					
40	3.8**	4.8	8.6	1/6	1140
62	3.8**	4.8	8.6	1/6	1140
77					
104	3.8**	4.8	8.6	1/6	1140
125	3.8**	4.8	8.6	1/6	1140
144					
164					
200	4.4**	5.5	9.9	1/4	1140
237	4.4**	5.5	9.9	1/4	1140
285	7.8**	9.8	17.6	1/2	1140
<b>208-230/460/3/60 [SV=4, 5 or 6]</b>					
40	2.2-2.3/1.1**	2.8-2.9/1.4	5.0-5.2/2.5	1/2	1175
62	2.2-2.3/1.1**	2.8-2.9/1.4	5.0-5.2/2.5	1/2	1175
77	2.2-2.3/1.1**	2.8-2.9/1.4	5.0-5.2/2.5	1/2	1175
104	2.2-2.3/1.1**	2.8-2.9/1.4	5.0-5.2/2.5	1/2	1175
125	2.2-2.3/1.1**	2.8-2.9/1.4	5.0-5.2/2.5	1/2	1175
144	2.2-2.3/1.1**	2.8-2.9/1.4	5.0-5.2/2.5	1/2	1175
164	2.2-2.3/1.1**	2.8-2.9/1.4	5.0-5.2/2.5	1/2	1175
200	2.2-2.3/1.1**	2.8-2.9/1.4	5.0-5.2/2.5	1/2	1175
237	2.2-2.3/1.1**	2.8-2.9/1.4	5.0-5.2/2.5	1/2	1175
285	2.2-2.3/1.1**	2.8-2.9/1.4	5.0-5.2/2.5	1/2	1175
317	3.1-3.2/1.6**	3.9-4.0/2.0	7.0-7.2/3.6	3/4	1145
367	3.1-3.2/1.6**	3.9-4.0/2.0	7.0-7.2/3.6	3/4	1145
495	4.6-4.7/2.3**	5.8-5.9/2.9	10.4-10.6/5.2	1-1/2	1175
585	4.6-4.7/2.3**	5.8-5.9/2.9	10.4-10.6/5.2	1-1/2	1175
700	10.0/5.0‡	12.5/6.3	22.5/11.3	3	1150

\* Optional variable speed switch is available.

\*\* These motors have automatic thermal overload protection or impedance protection.

† These motors are without thermal overload protection. Motors without thermal overload protection must be installed with the optional manual starter or other field provided overload protection.

‡ These motors are 230/460 volts only.

NOTE 3: Models 317 through 700 are not available for either Totally Enclosed or Explosion Proof with Overload 115/1/60 motor types.

**CAUTION: Select appropriate AMP, MCA, and MOP for the multiple voltage motors. For example, the AMP, MCA, and MOP for Model 40 with a 230 volt Totally Enclosed motor is 1.1, 1.4, and 2.5 respectively.**

# Horizontal and Vertical Unit Heater Piping and Installation

The illustrations below depict different typical piping configurations. Proper selection should be based on the operational characteristics of the source supply. For selection and sizing of piping, traps, filters and other piping specialties, ASHRAE guides and specialty manufacturer's literature should be consulted. We assume that the type and total design of systems has been selected or approved by a qualified engineer. The installation and service manual should be consulted for further information on installation, operation, drainage and system cleaning.

Piping and installation is typical for both horizontal and vertical unit heaters – except side connections Figure 13.

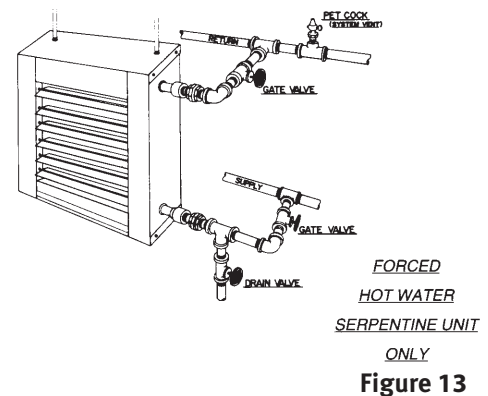
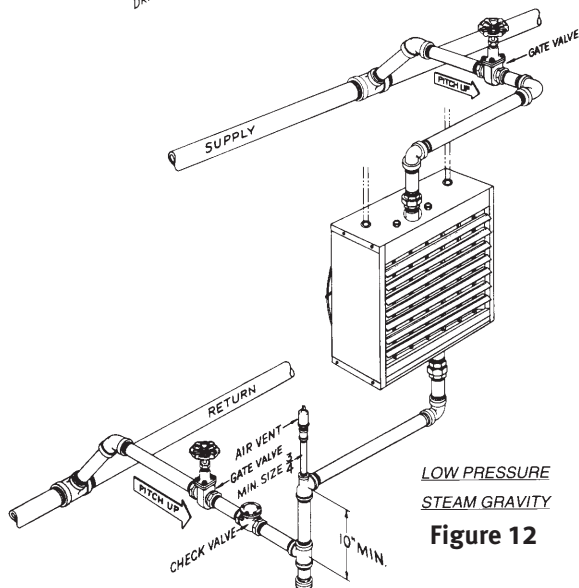
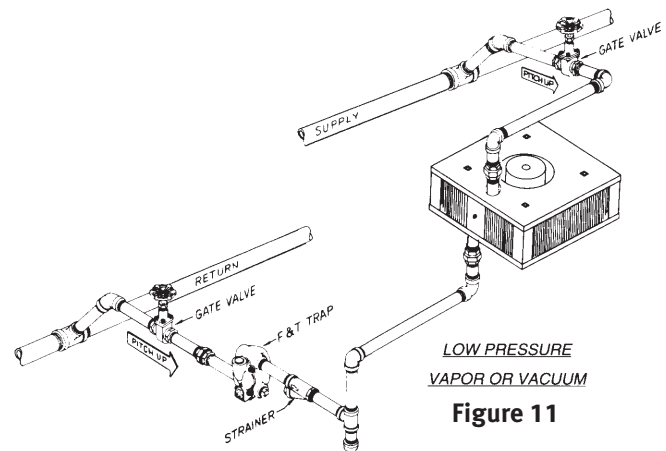
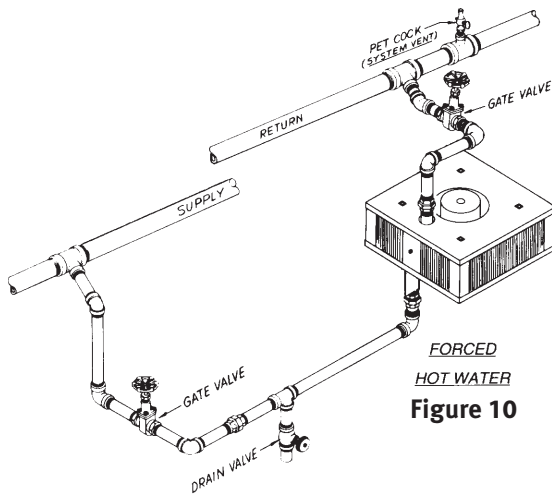
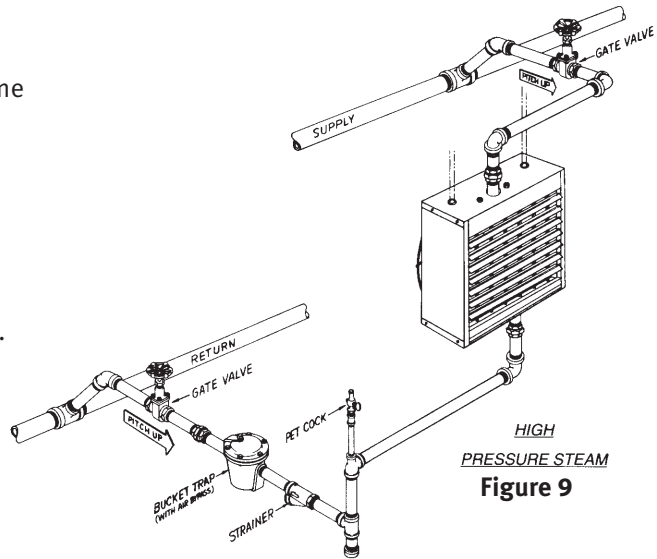

# Wiring Diagrams – Figure 14

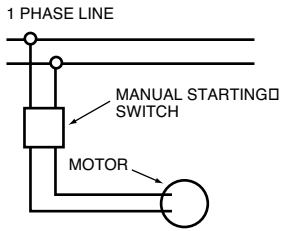

**MANUAL CONTROL WITH SINGLE PHASE MOTOR**

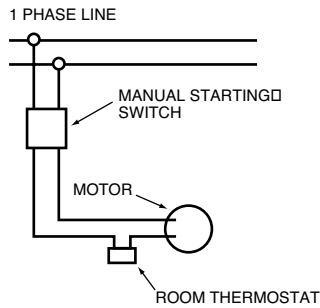

**THERMOSTATIC CONTROL WITH MANUAL STARTER**

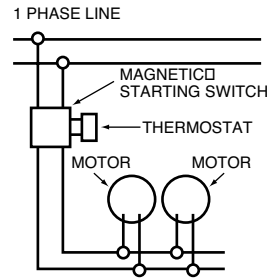

**THERMOSTATIC CONTROL USING MAGNETIC STARTER OPERATING SEVERAL UNITS**

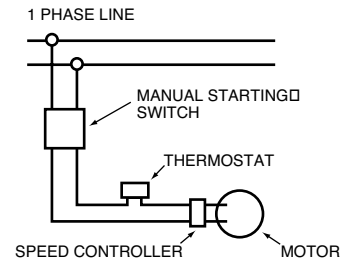

**SPEED CONTROLLER WITH MANUAL STARTING SWITCH**

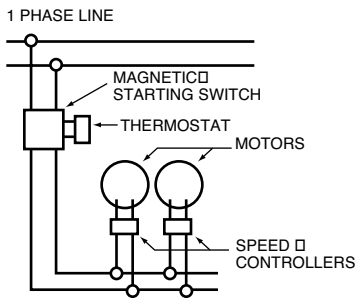

**SPEED CONTROLLERS WITH MAGNETIC STARTING SWITCH FOR OPERATING SEVERAL UNITS**

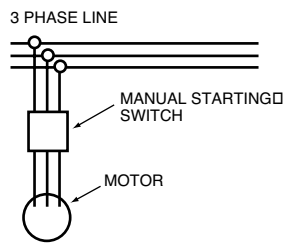

**MANUAL CONTROL WITH THREE PHASE MOTOR**

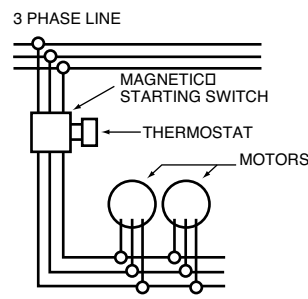

**THERMOSTATIC CONTROL OF SEVERAL THREE PHASE UNITS**

1. For internal wiring and overload protection on all starters, consult the control manufacturer for details.
2. When using thermostatic control with a manual starter, be sure that the electrical rating of the thermostat is sufficient to carry the motor current.
3. Refer to pages 13 and 25 for motor characteristics of individual unit heaters.

## Warranty

### STEAM/HOT WATER UNIT HEATER WARRANTY

The products in this catalog are warranted by the manufacturer to be free from defects in material and workmanship for a period of one (1) year from the date of shipment from the manufacturer's plant. The manufacturer's liability under this warranty is limited to replacing or repairing at our option, F.O.B. our plant any defective component or assembly returned to our factory prepaid and with proper return authorization documents. All repairs or replacements are made subject to factory inspection. No liability is accepted for consequential damages, freight or labor charges.

This warranty does not cover damages or failure due to improper installation or piping, corrosive atmospheric conditions, misuse or negligence by others.

### TERMS OF SALE

- No obligation is assumed by this corporation to sell to anyone holding this book any of the items listed herein.
- An order is not a valid order until acknowledged by the manufacturer.
- The manufacturer reserves the right to make changes in design, material or accessory vendors without notice and without obligation to incorporate such changes in products of prior manufacture.
- Additional sales and freight terms are contained in the price list.

# Horizontal Hydronic Unit Heaters Model Number Description

Digit	H	X	X	X	—	1	2	3	4	5	6	7	8	9	†
Item	Prefix					UT	CT		CA	SV	MT	AS			

(Internal use Only)

## 1, 2 - Unit Type [UT]

HS - Horizontal

## 3 - Coil Type [CT]

A - Serpentine  
B - Standard (Header Type)

## 4, 5, 6 - Capacity [CA]

### Coil Type [A] Serpentine\*

108 - 8,030 BTU/HR (2.4 kW)      125 - 24,800 BTU/HR (7.3 kW)  
118 - 18,400 BTU/HR (5.4 kW)      136 - 35,900 BTU/HR (10.5 kW)

\*Based on 200°F EWT, 60°F EAT, 20°F TD

### Coil Type [B] Standard\*\*

018 - 18,000 BTU/HR (5.3 kW)	096 - 96,000 BTU/HR (28.1 kW)	204 - 204,000 BTU/HR (59.8 kW)
024 - 24,000 BTU/HR (7.0 kW)	108 - 108,000 BTU/HR (31.6 kW)	240 - 240,000 BTU/HR (70.3 kW)
036 - 36,000 BTU/HR (10.5 kW)	120 - 120,000 BTU/HR (35.2 kW)	280 - 280,000 BTU/HR (82.0 kW)
048 - 48,000 BTU/HR (14.1 kW)	132 - 132,000 BTU/HR (38.7 kW)	300 - 300,000 BTU/HR (87.9 kW)
060 - 60,000 BTU/HR (17.6 kW)	144 - 144,000 BTU/HR (42.2 kW)	360 - 360,000 BTU/HR (105.5 kW)
072 - 72,000 BTU/HR (21.1 kW)	156 - 156,000 BTU/HR (45.7 kW)	
084 - 84,000 BTU/HR (24.6 kW)	180 - 180,000 BTU/HR (52.7 kW)	

\*\*Based on 2 psi steam

## 7 - Supply Voltage [SV]

1 - 115/1/60      5 - 230/3/60  
3 - 230/1/60      6 - 460/3/60  
4 - 208/3/60      Z - Other

## 8 - Motor Type [MT]

1 - Standard Motor  
2 - Explosion Proof

## 9 - Accessories [AS]

All Field Installed Accessories are to be entered as a separate line item using the catalog number which utilizes "AS" as a prefix. i.e: G6 becomes AS-G6.

### FACTORY INSTALLED

M6 - OSHA Fan Guard\*\*\*  
(1 Phase Motors Only)  
M9 - Standard Fan Guard  
(3 Phase or Explosion Proof Motors Only)  
\*\*\* OSHA Fan Guard Standard on sizes 108A through 136A and 18 through 48 (with 1 Phase Standard Motors Only)

V1 - Phenolic Coating (Air Dried)  
V2 - Phenolic Coating (Baked)  
V5 - Phenolic Coating (Air Dried)  
Optional Vertical Louvers  
V6 - Phenolic Coating (Baked)  
Optional Vertical Louvers

### FIELD INSTALLED (AS-\_\_\_\_)

G6 - Locking Thermostat Cover  
For Accessory U3-EXP Only

L2-1 - 115/230V Single Phase  
Disconnect Switch - Non Fused  
L2-2 - 208/230V 3 Phase  
Disconnect Switch - Non Fused  
L2-3 - 460/575V 3 Phase  
Disconnect Switch - Non Fused

Q6H - Vertical Louvers

U3-EXP - Explosion Proof Line Voltage Stat - Heavy Duty†  
U5 - Strap on Hot Water Control  
U6 - Steam Pressure Control  
(Open on rise in pressure)  
U7 - Steam Pressure Control  
(Close on rise in pressure)  
U8 - 5.0 Amp Speed Control Switch  
(Capacities [CA] 108A-136A and 18-108 Only)  
U9 - Manual Starters - 1 Phase  
U0 - Manual Starters - 3 Phase

W5 - Line Voltage Thermostat w/Fan Switch†  
W6 - Programmable Line Voltage Thermostat  
w/Fan Switch†  
† All thermostats are 115V

# Vertical Hydronic Unit Heaters Model Number Description

Digit	V	X	X	X	—	1	2	3	4	5	6	7	8	9	†
Item	Prefix					UT	CT		CA	SV	MT	AC			

(Internal use Only)

## 1, 2 - Unit Type [UT]

V5 - Vertical

## 3 - Coil Type [CT]

B - Standard

## 4, 5, 6 - Capacity [CA]\*

040 - 40,000 BTU/HR (11.7 kW)	237 - 237,000 BTU/HR (69.5 kW)
062 - 62,000 BTU/HR (18.2 kW)	285 - 285,000 BTU/HR (83.5 kW)
077 - 77,000 BTU/HR (22.6 kW)	317 - 317,000 BTU/HR (92.9 kW)
104 - 104,000 BTU/HR (30.5 kW)	367 - 367,000 BTU/HR (107.6 kW)
125 - 125,000 BTU/HR (36.6 kW)	495 - 495,000 BTU/HR (145.1 kW)
144 - 144,000 BTU/HR (42.2 kW)	585 - 585,000 BTU/HR (171.4 kW)
164 - 164,000 BTU/HR (48.1 kW)	700 - 700,000 BTU/HR (205.1 kW)
200 - 200,000 BTU/HR (58.6 kW)	

\*Based on 2 psi steam

## 7 - Supply Voltage [SV]

1 - 115/1/60      6 - 460/3/60  
4 - 208/3/60      Z - Other  
5 - 230/3/60

## 8 - Motor Type [MT]

1 - Standard  
2 - Explosion Proof

## 9 - Accessories [AS]

All Field Installed Accessories are to be entered as a separate line item using the catalog number which utilizes "AS" as a prefix. i.e: G6 becomes AS-G6.

### FACTORY INSTALLED

M6 - OSHA Fan Guard  
V1 - Phenolic Coating (Air Dried)  
V2 - Phenolic Coating (Baked)

### FIELD INSTALLED (AS-\_\_\_\_)

G6 - Locking Thermostat Cover  
For Accessory U3-EXP Only

L2-1 - 115/230V Single Phase  
Disconnect Switch - Non Fused  
L2-2 - 208/230V 3 Phase  
Disconnect Switch - Non Fused  
L2-3 - 460/575V 3 Phase  
Disconnect Switch - Non Fused

Q8 - Louver Cone Diffuser

U3-EXP - Explosion Proof Line Voltage Stat - Heavy Duty†  
U5 - Strap on Hot Water Control  
U6 - Steam Pressure Control  
(Open on rise in pressure)  
U7 - Steam Pressure Control  
(Close on rise in pressure)  
U8 - 5.0 Amp Speed Control Switch  
(Capacities [CA] 040-104 Only)  
U9 - Manual Starters - 1 Phase  
U0 - Manual Starters - 3 Phase

V7 - Phenolic Coating - Louver Cone Diffuser\*\*  
\*\*Will match phenolic type selected for unit  
(Air Dried or Baked).

W5 - Line Voltage Thermostat w/Fan Switch†  
W6 - Programmable Line Voltage Thermostat  
w/Fan Switch†  
† All thermostats are 115V

 **STERLING**  
HVAC PRODUCTS  
260 NORTH ELM ST. WESTFIELD, MA 01085  
(413) 564-5540  
www.sterlinghvac.com

 A MESTEK COMPANY

  
C LISTED US  
Intertek